

UNIDAD IX: PROYECTO ARQUITECTONICO

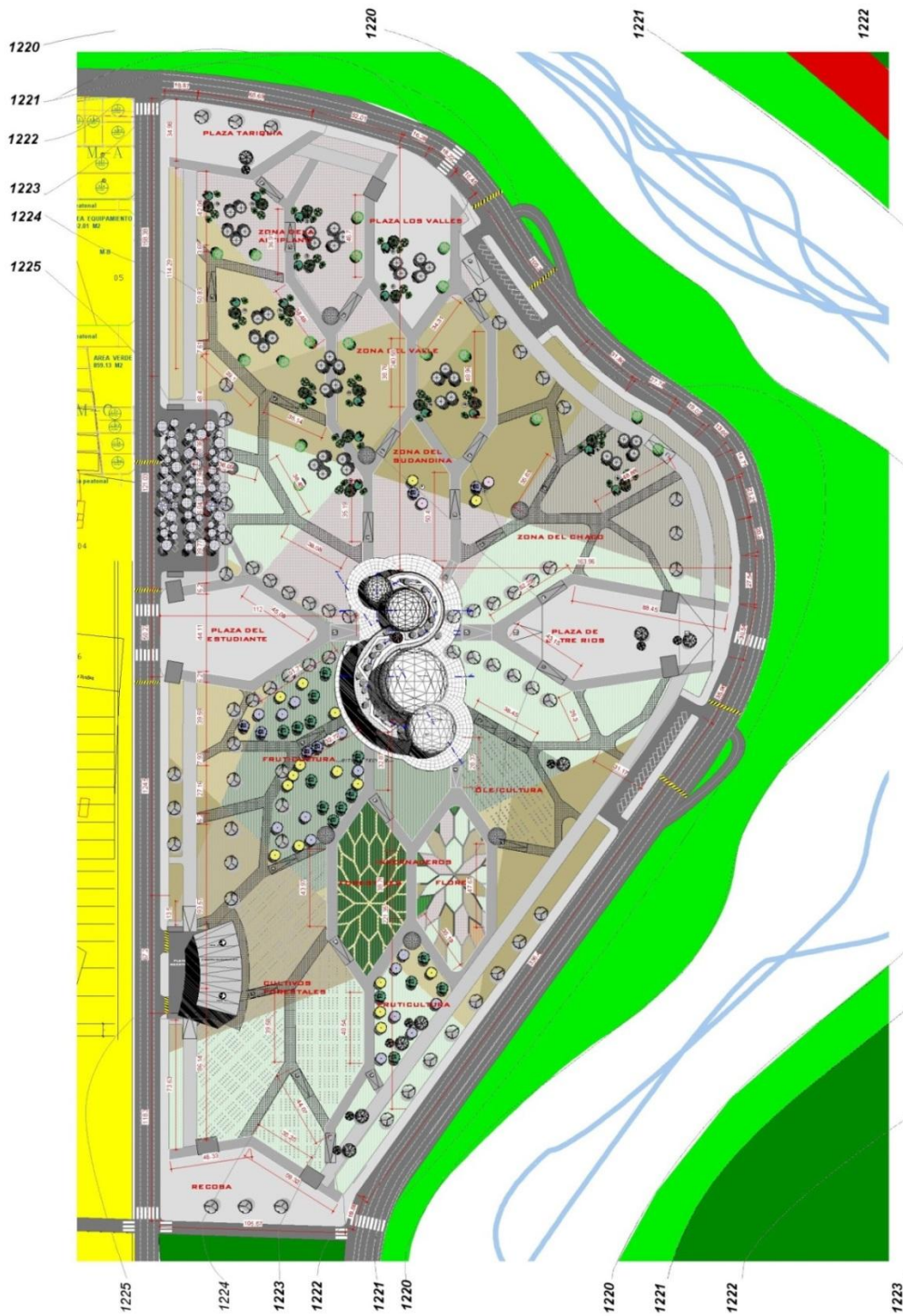

Planimetría general

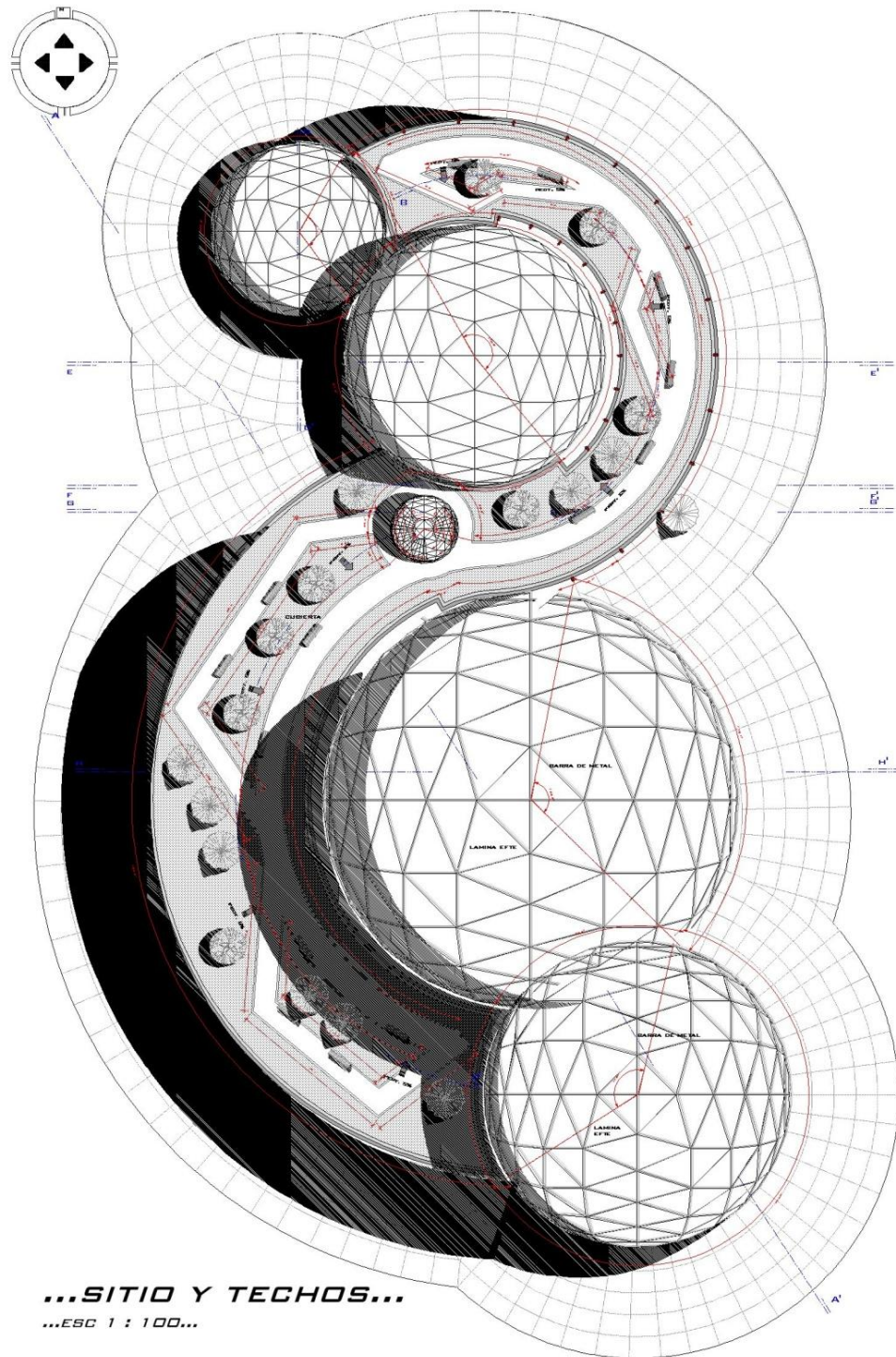

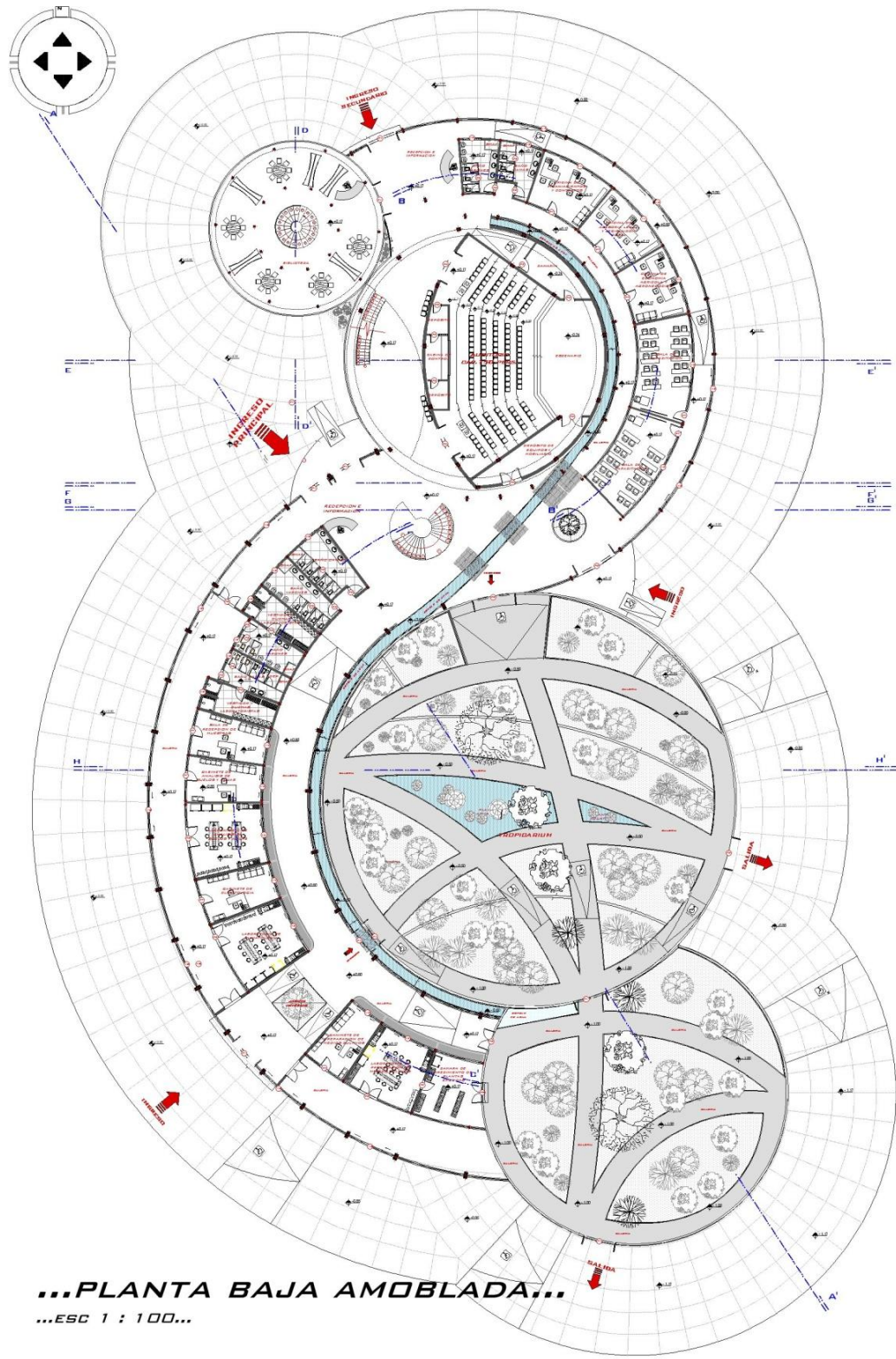

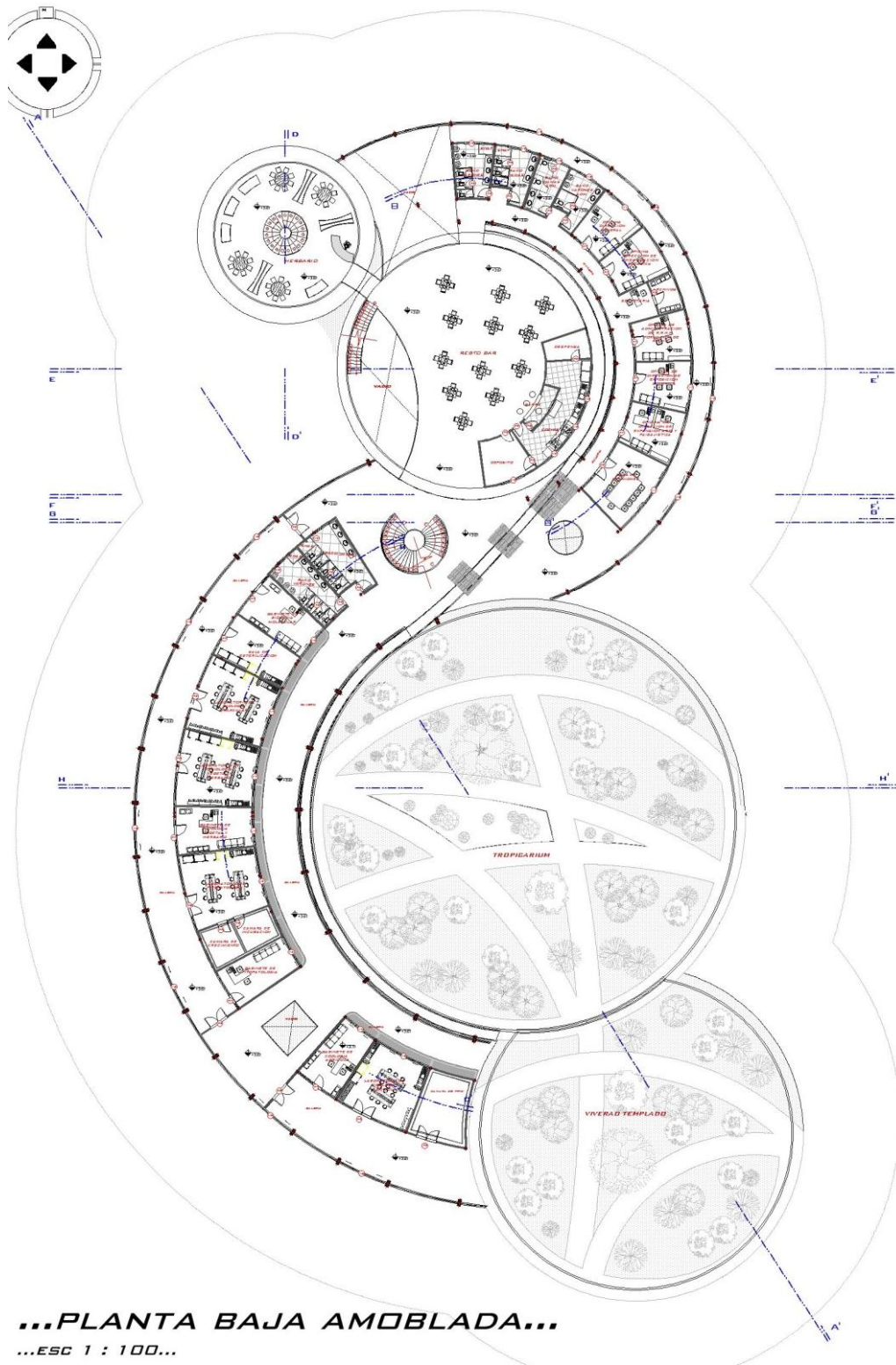

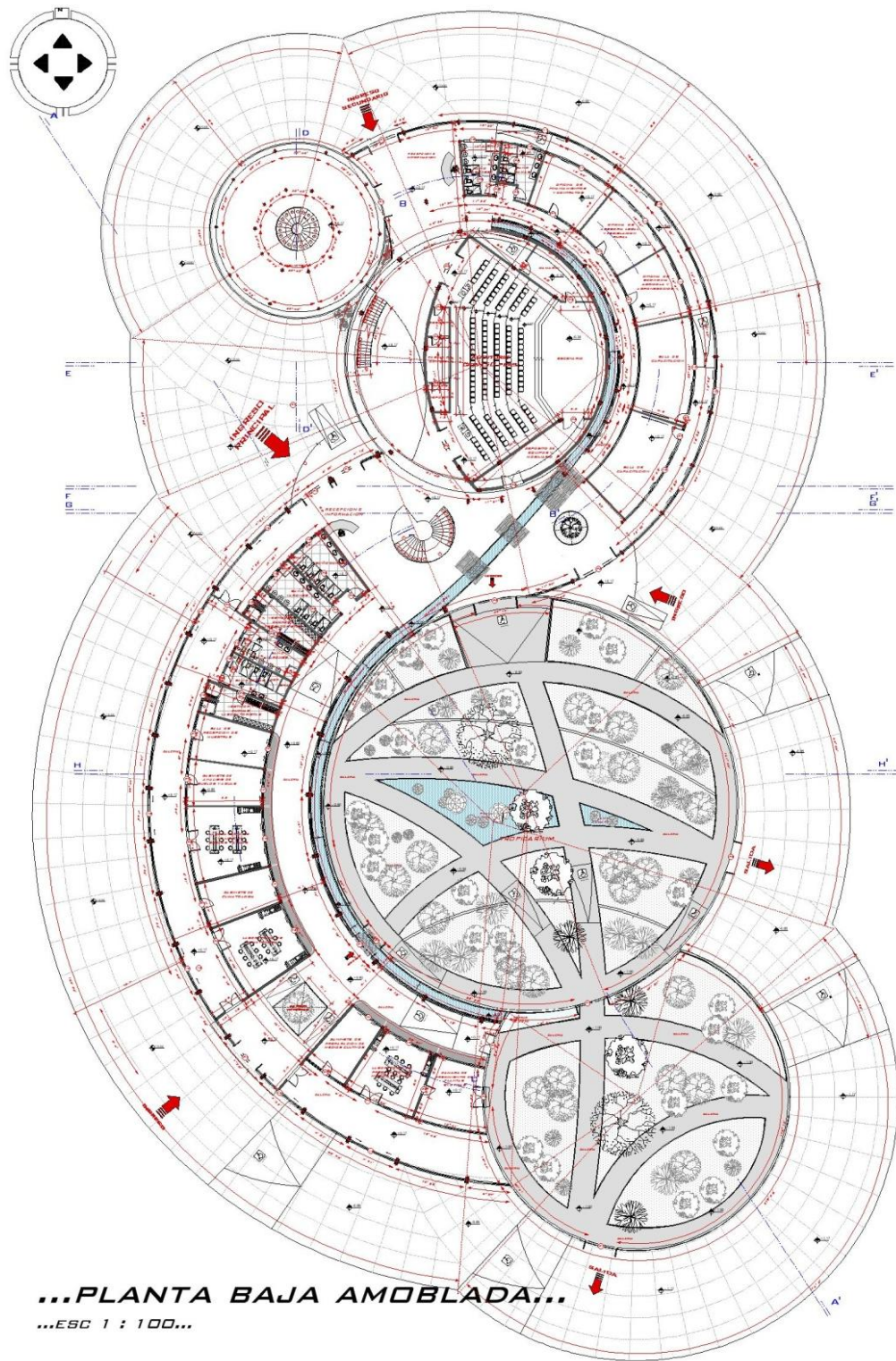

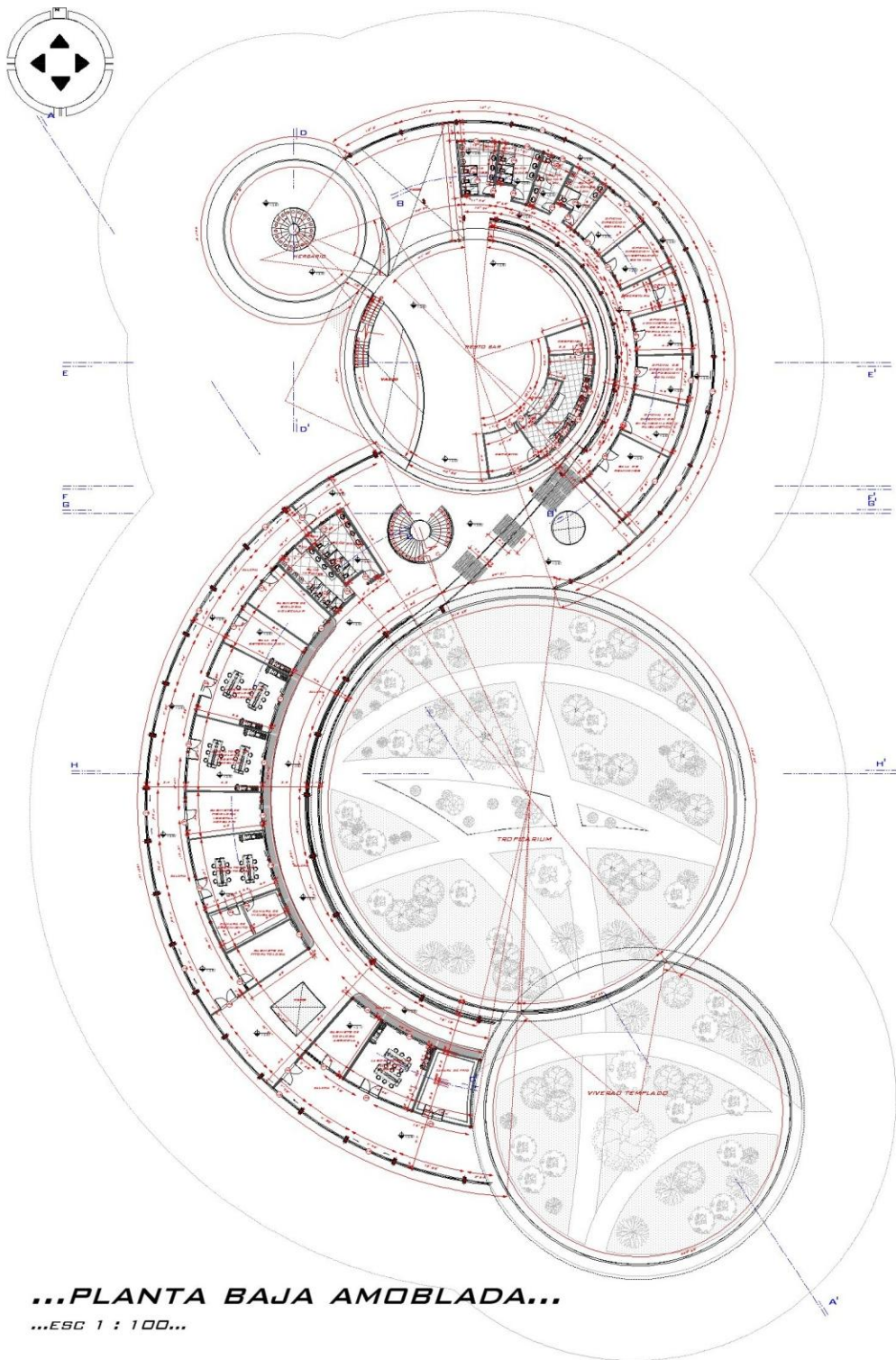

# Pabellón Botánico Natural para la ZA de la RNFFT

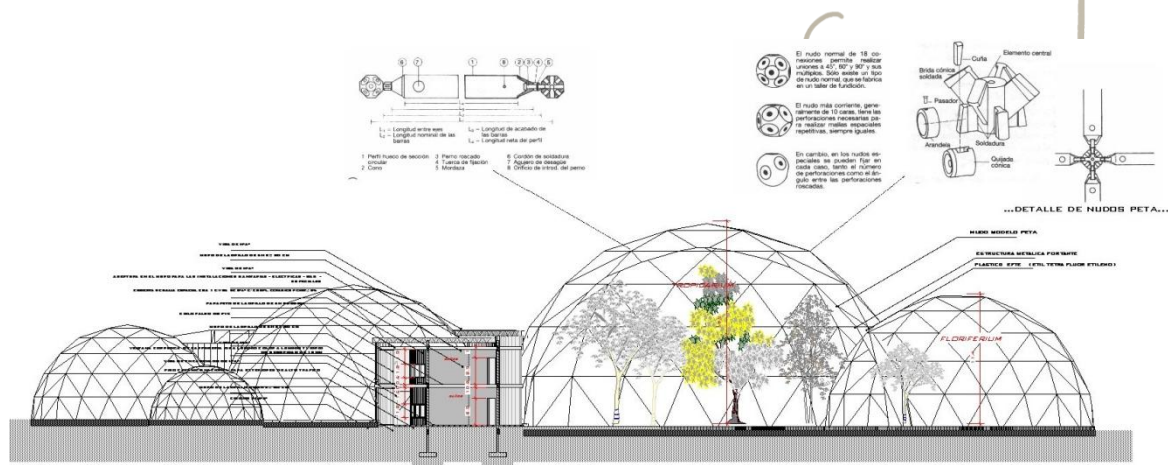

...CORTE LONGITUDINAL DE CONJUNTO A'-A...  
...ESC 1 : 200...

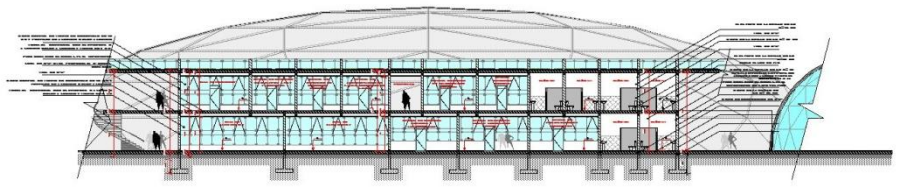

...CORTE LONGITUDINAL B'-B AREA ADMINISTRATIVA...  
...ESC 1 : 200...

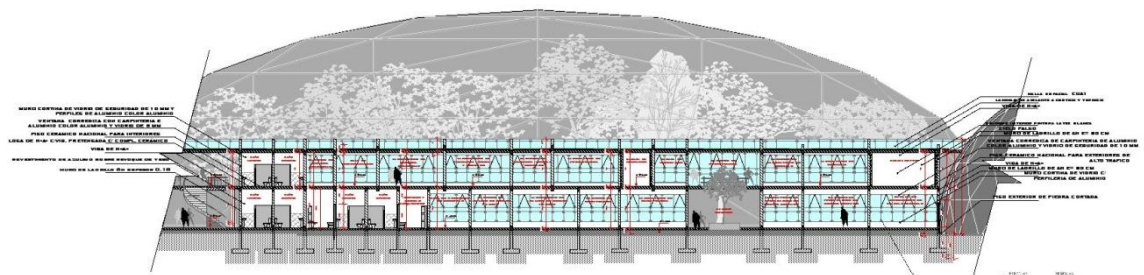

...CORTE LONGITUDINAL C'-C AREA DE INVESTIGACION...  
...ESC 1 : 200...

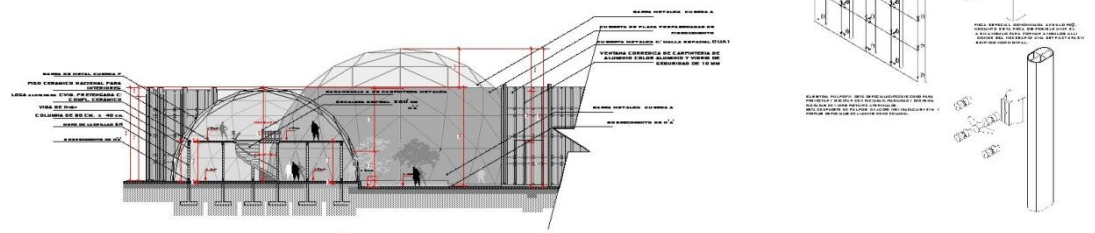

...CORTE TRANSVERSAL D-D' AREA COMPLEMENTARIA...  
...ESC 1 : 200...

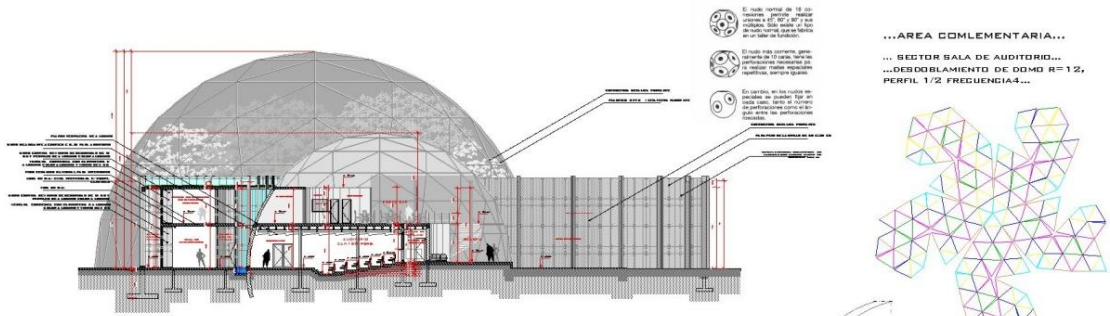

...CORTE TRANSVERSAL E-E' AREA COMPLEMENTARIA...

...ESC 1 : 200...

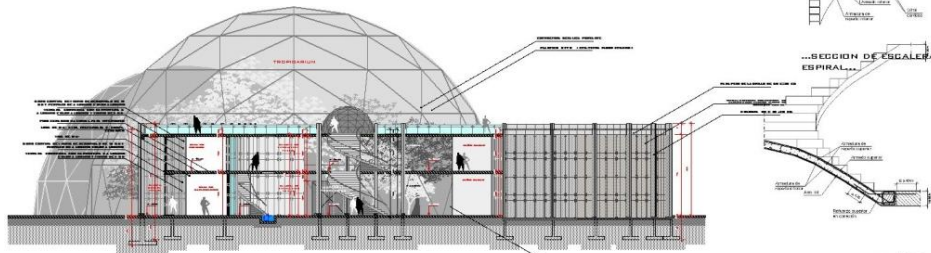

...CORTE TRANSVERSAL F-F' AREA DE DISTRIBUCION...

...ESC 1 : 200...

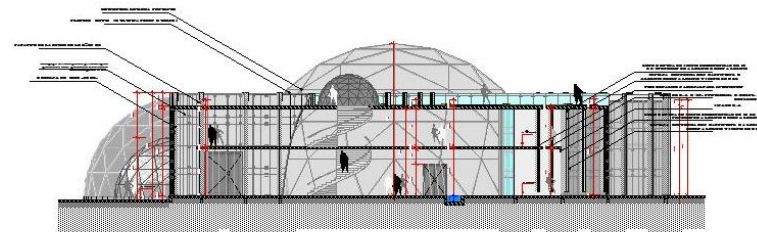

...CORTE TRANSVERSAL G-G' AREA DE DISTRIBUCION...

...ESC 1 : 200...

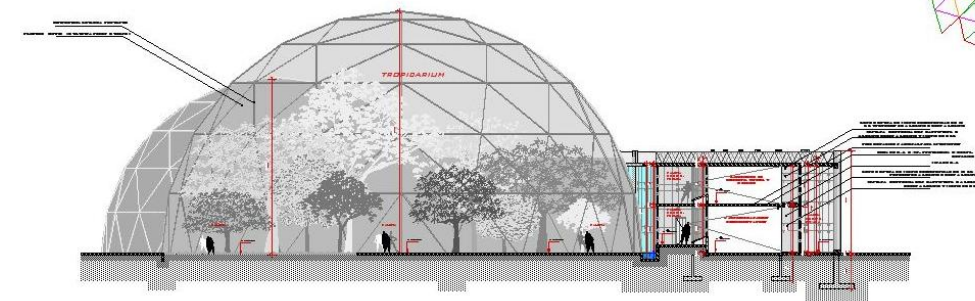

...CORTE TRANSVERSAL H-H' AREA DE DISTRIBUCION...

...ESC 1 : 200...



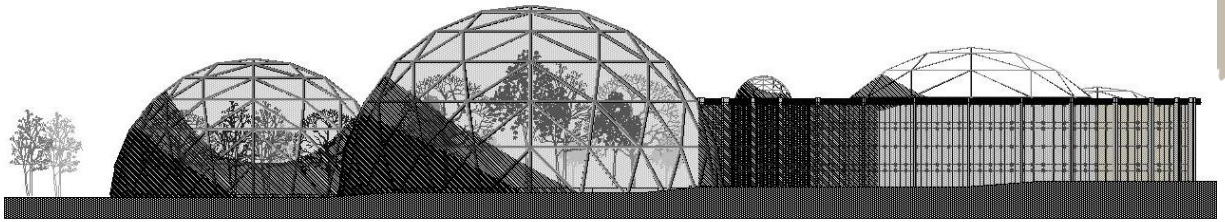

**...FACHADA ESTE\_POSTERIOR ...**

...ESG 1: 200...

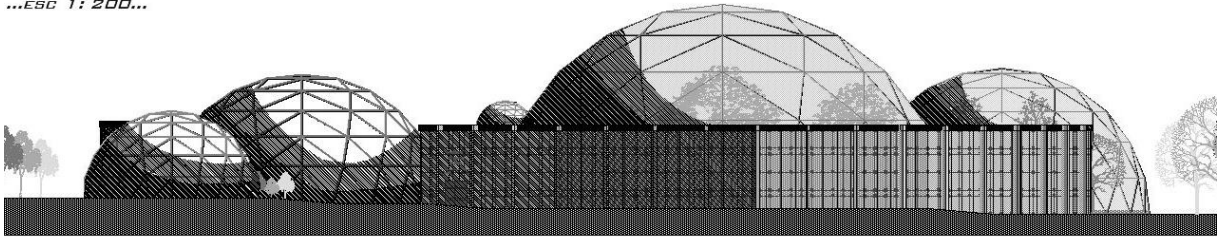

**...FACHADA OESTE\_FRONTAL ...**

...ESG 1: 200...

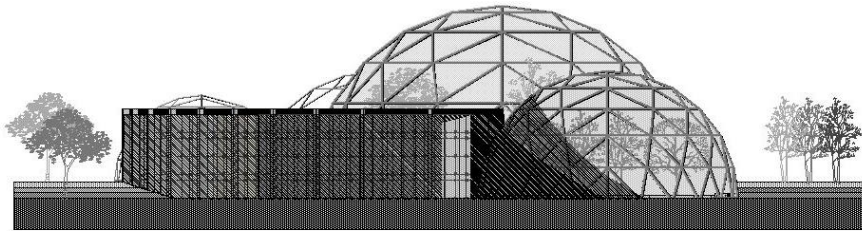

**...FACHADA NORTE\_LATERAL IZQUIERDA ...**

...ESG 1: 200...

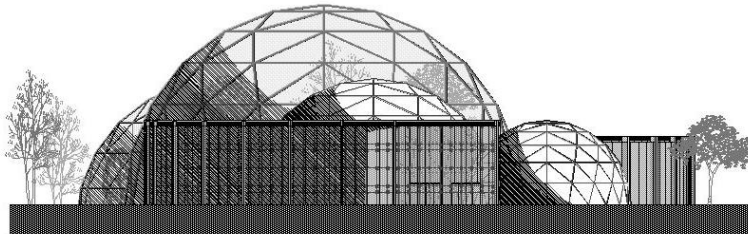

**...FACHADA SUR\_LATERAL DERECHA...**

...ESG 1: 200...

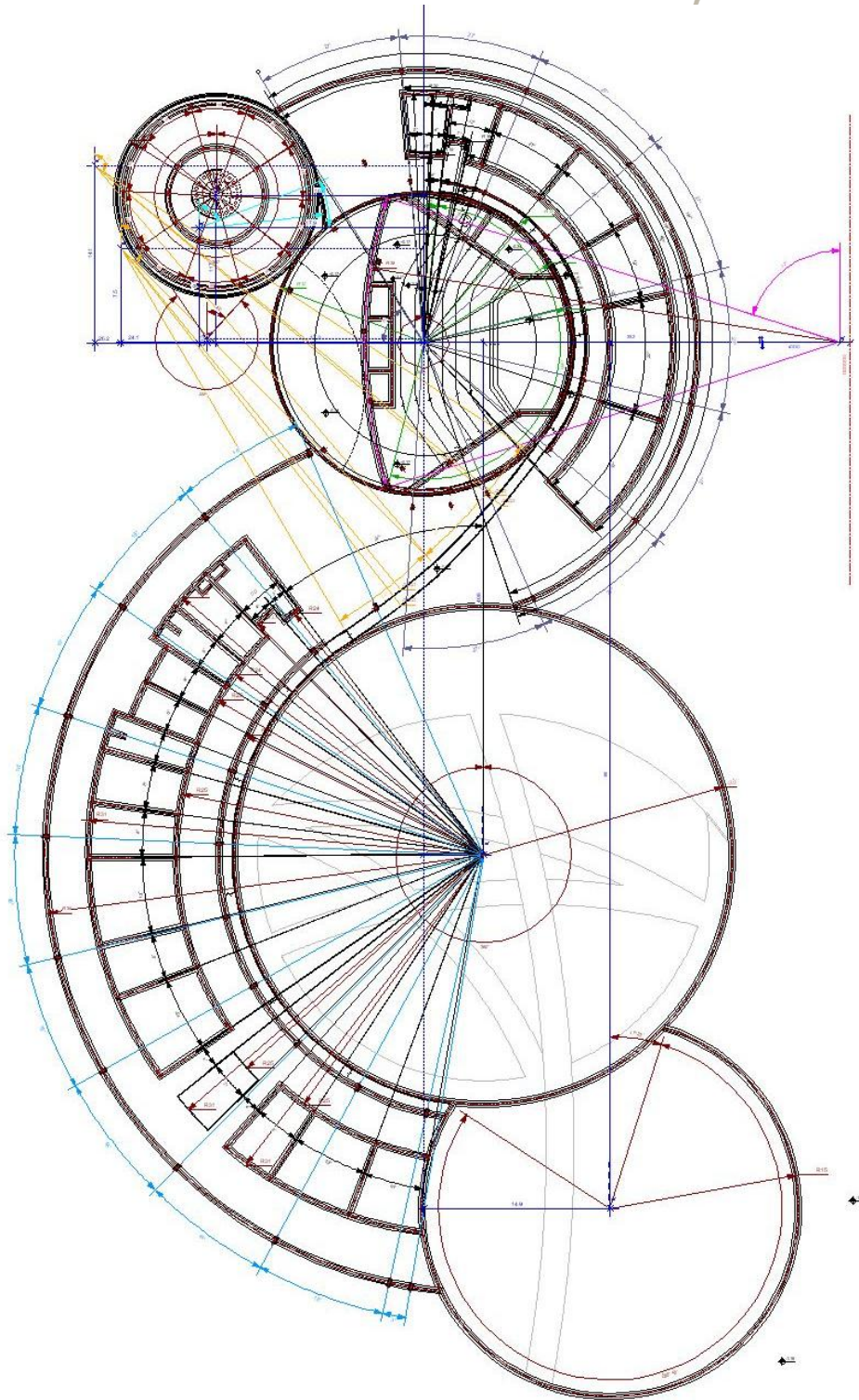

Planos de cimientos

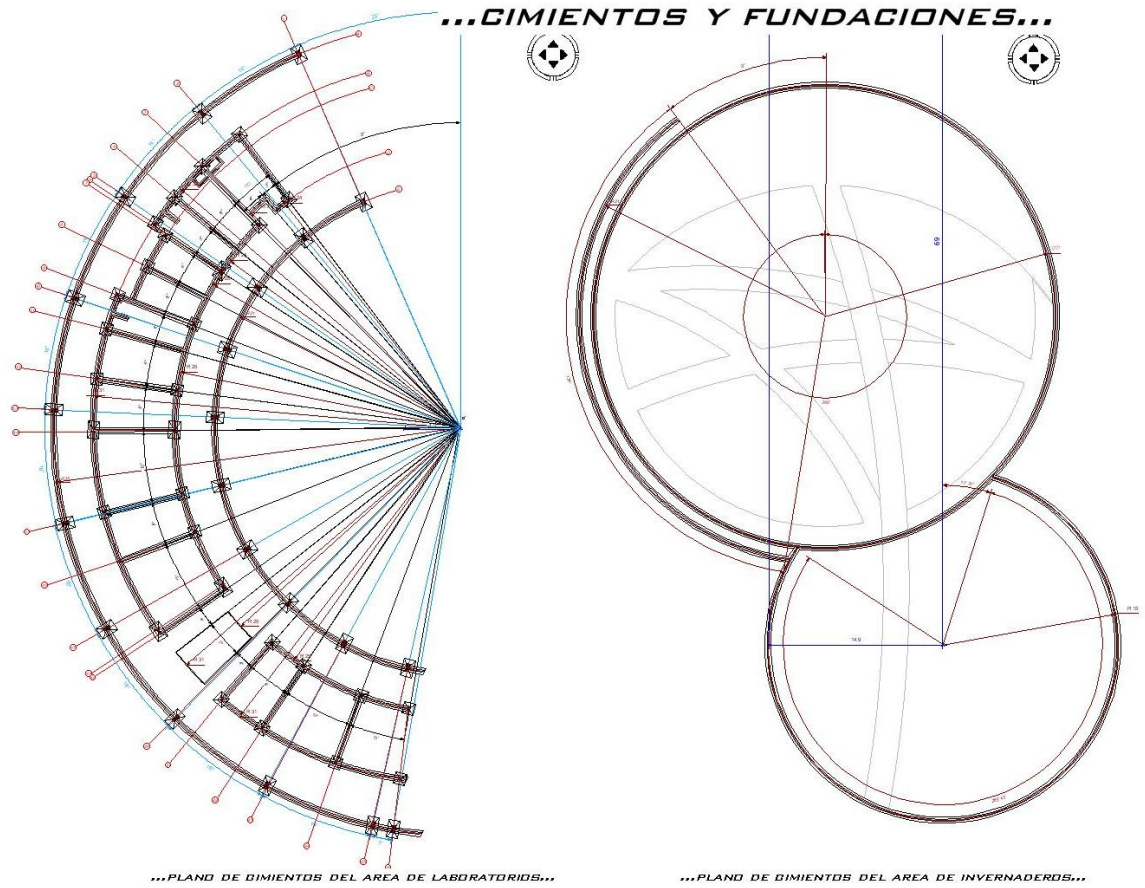

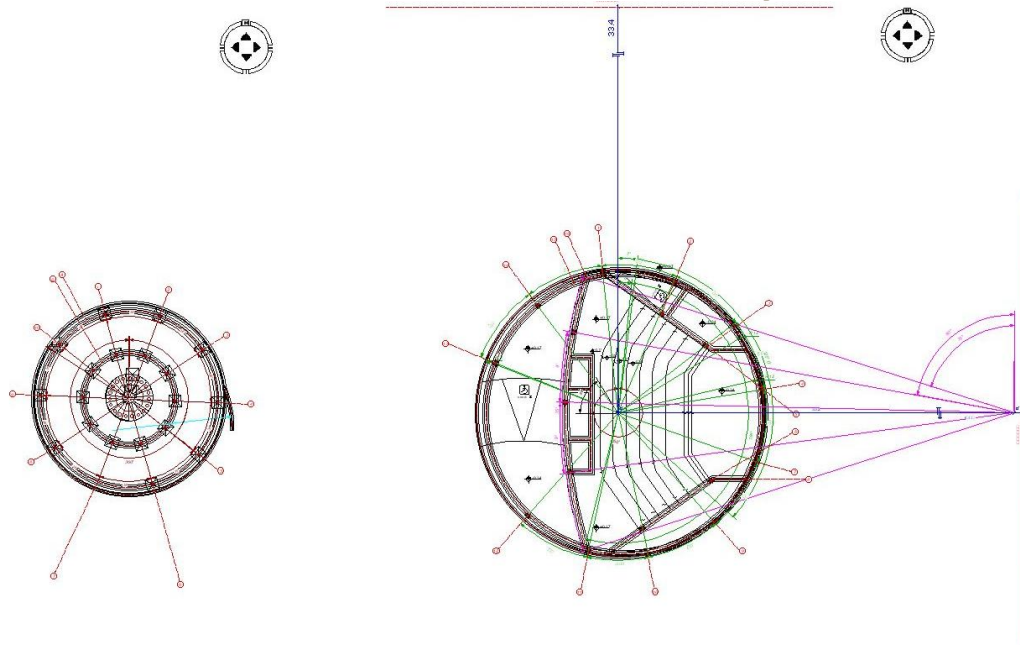

...PLANO DE CIMIENTOS DEL AREA DE BIBLIOTECA...  
...ESC 1: 100...

...PLANO DE CIMIENTOS DEL AREA COMPLEMENTARIA...  
...ESC 1: 100...

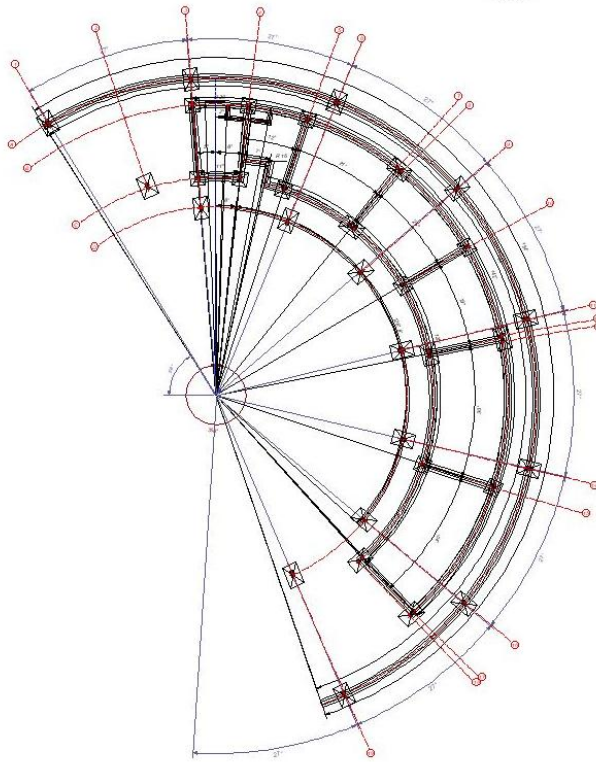

...PLANO DE CIMIENTOS DEL AREA ADMINISTRATIVA...  
...ESC 1: 100...

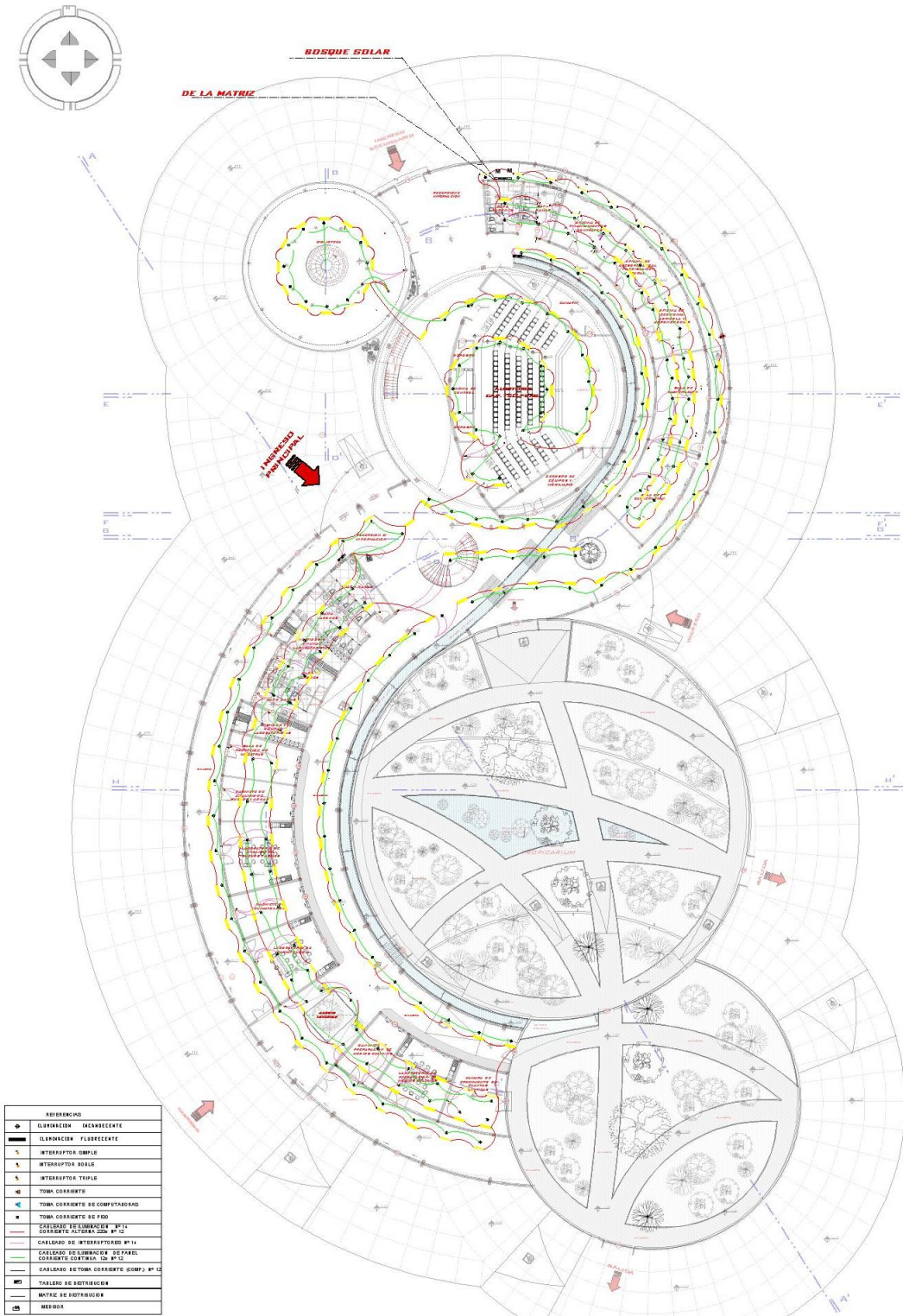

...INSTALACION ELECTRICA  
PLANTA BAJA...

...ESC 1 : 200...

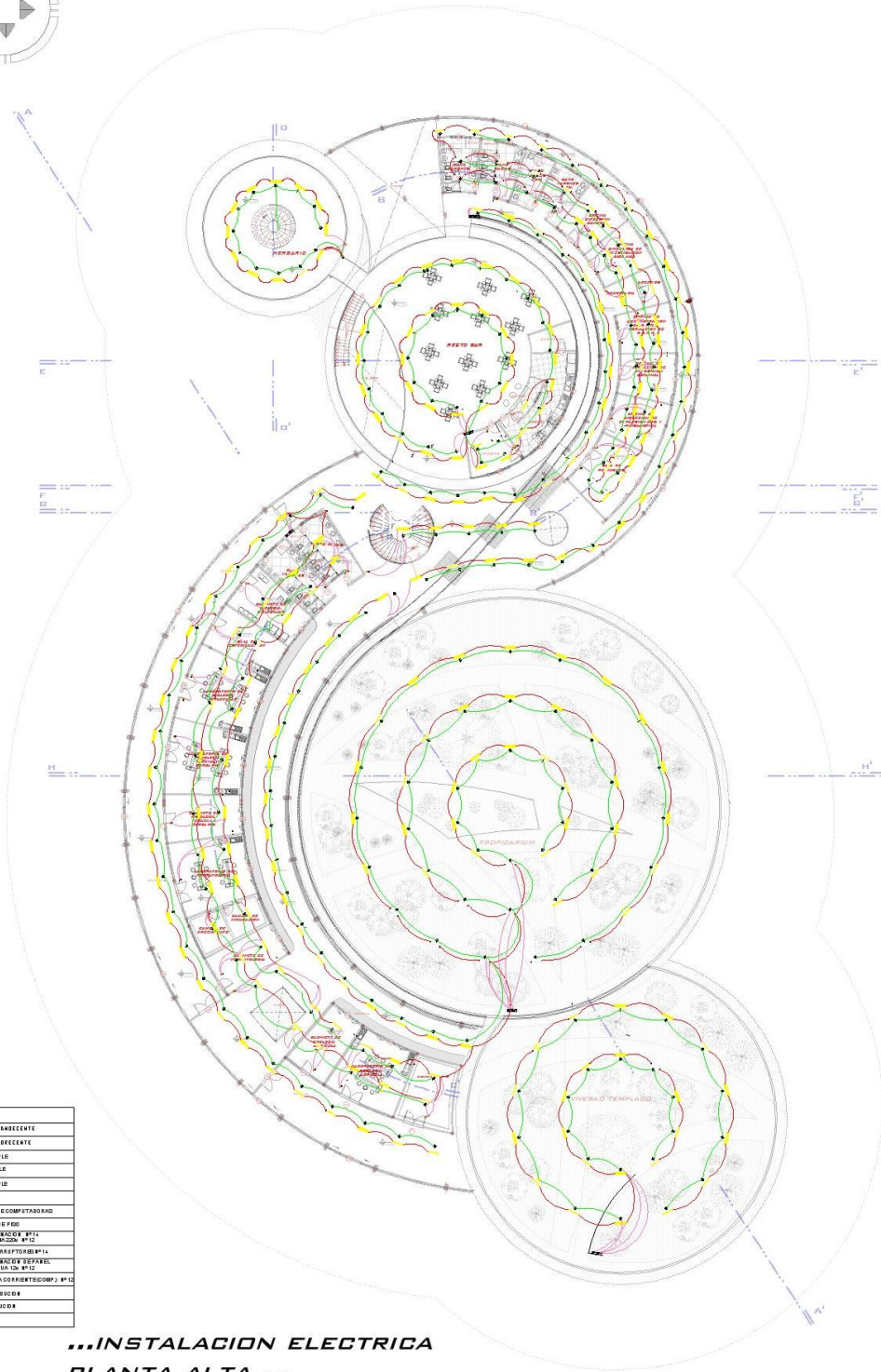
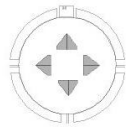

REFERENCIO	
◆	ILUMINACION INCANDESCENTE
◆	ILUMINACION FLUORESCENTE
■	INTERRUPTOR SIMPLE
□	INTERRUPTOR DOBLE
□	INTERRUPTOR TRIPLE
□	TOMA CORRIENTE
□	TOMA CORRIENTE CON INTERRUPTOR
□	TOMA CON INTERRUPTOR
□	CABLEADO DE ILUMINACION Nº10
□	CABLEADO DE ILUMINACION Nº12
□	CABLEADO DE INTERRUPTOR Nº14
□	CABLEADO DE ILUMINACION DE TABLERO
□	CABLEADO DE TOMA CORRIENTE Nº12
□	CABLEADO DE TOMA CORRIENTE Nº14
□	TABLERO DE DISTRIBUCION
□	MATIZ DE DISTRIBUCION
□	MEZCLA

**...INSTALACION ELECTRICA  
PLANTA ALTA ...**  
...ESC 1 : 200...

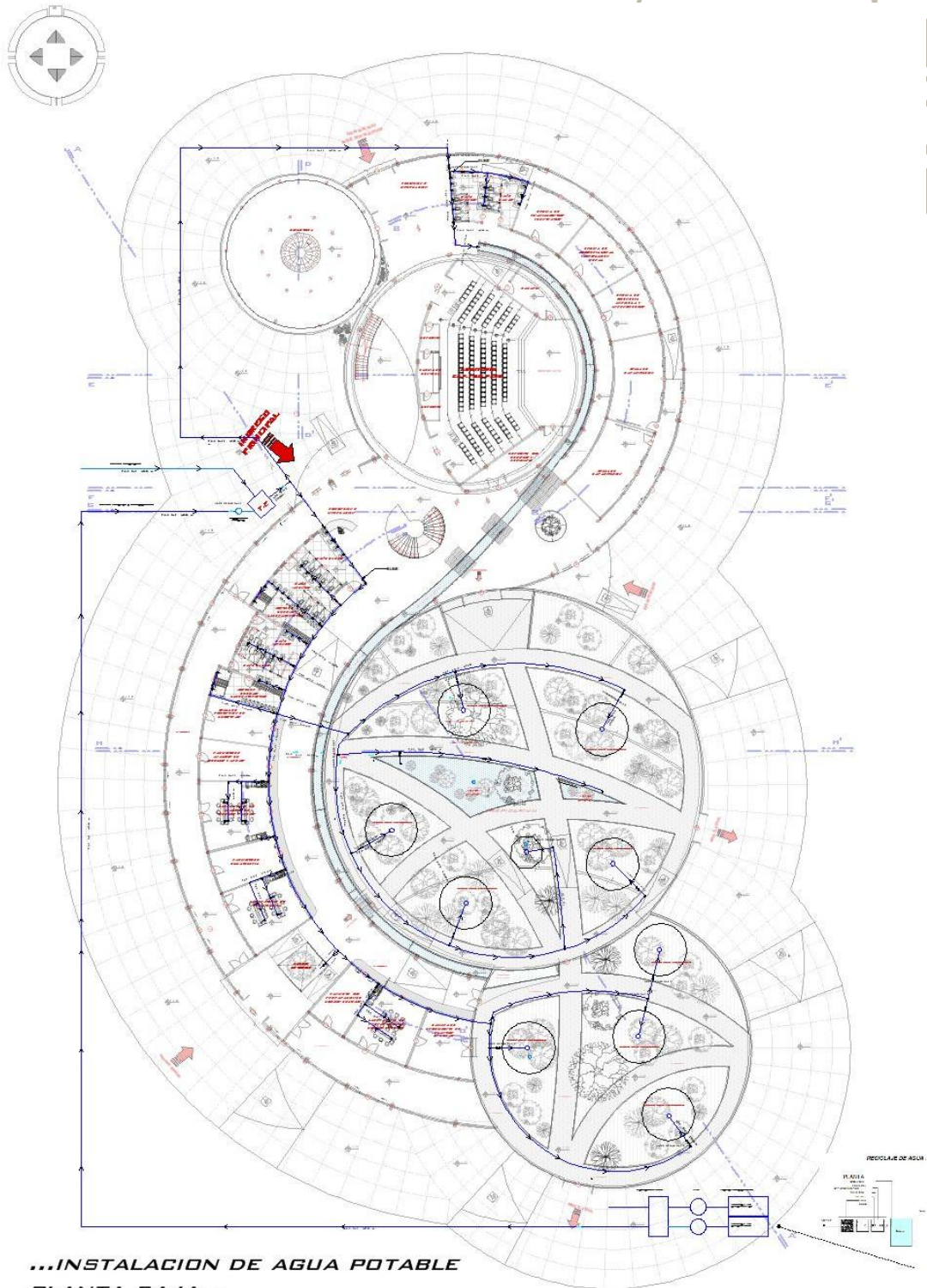

**...INSTALACION DE AGUA POTABLE  
PLANTA BAJA...**  
...ESG 1 : 200...

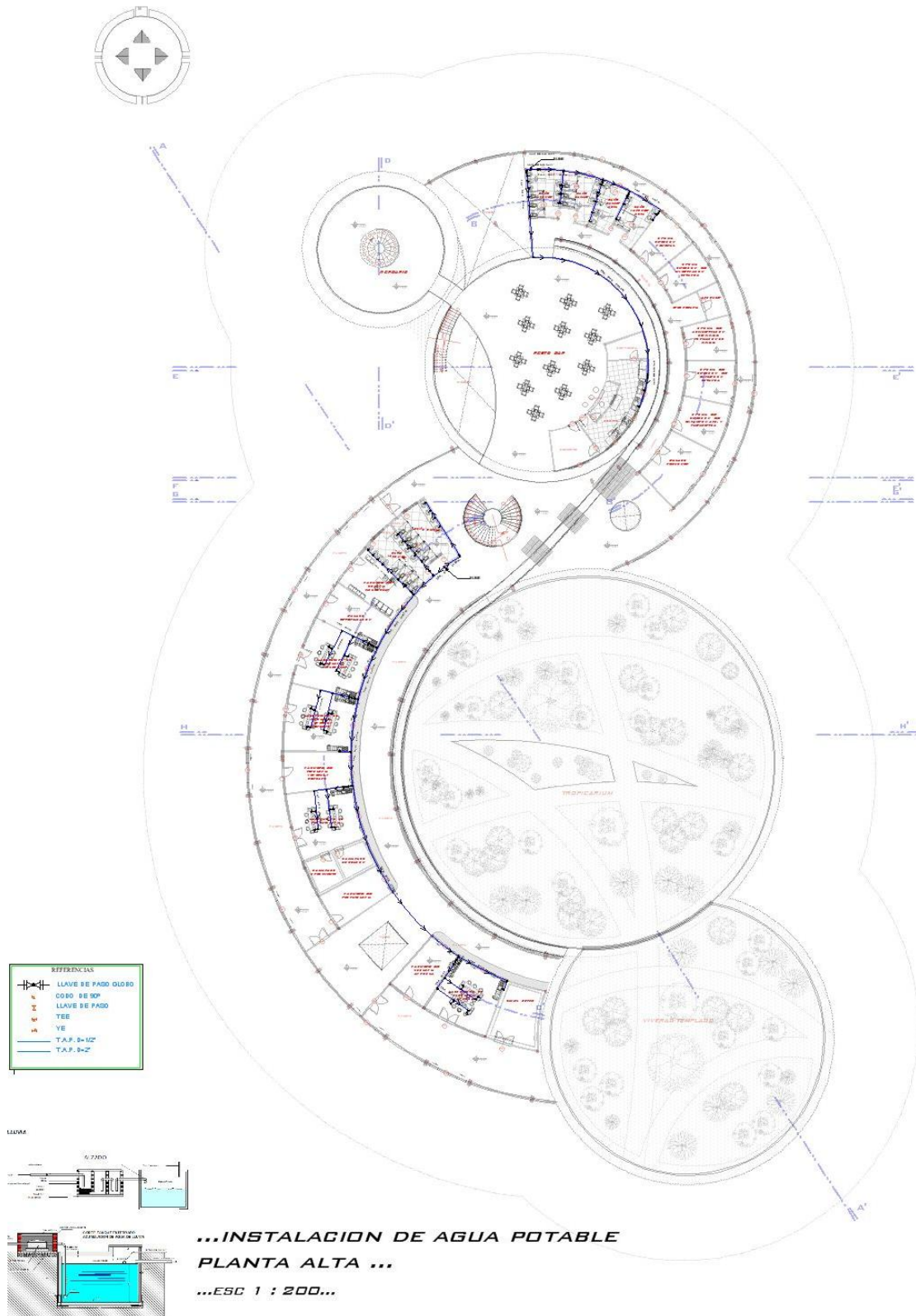



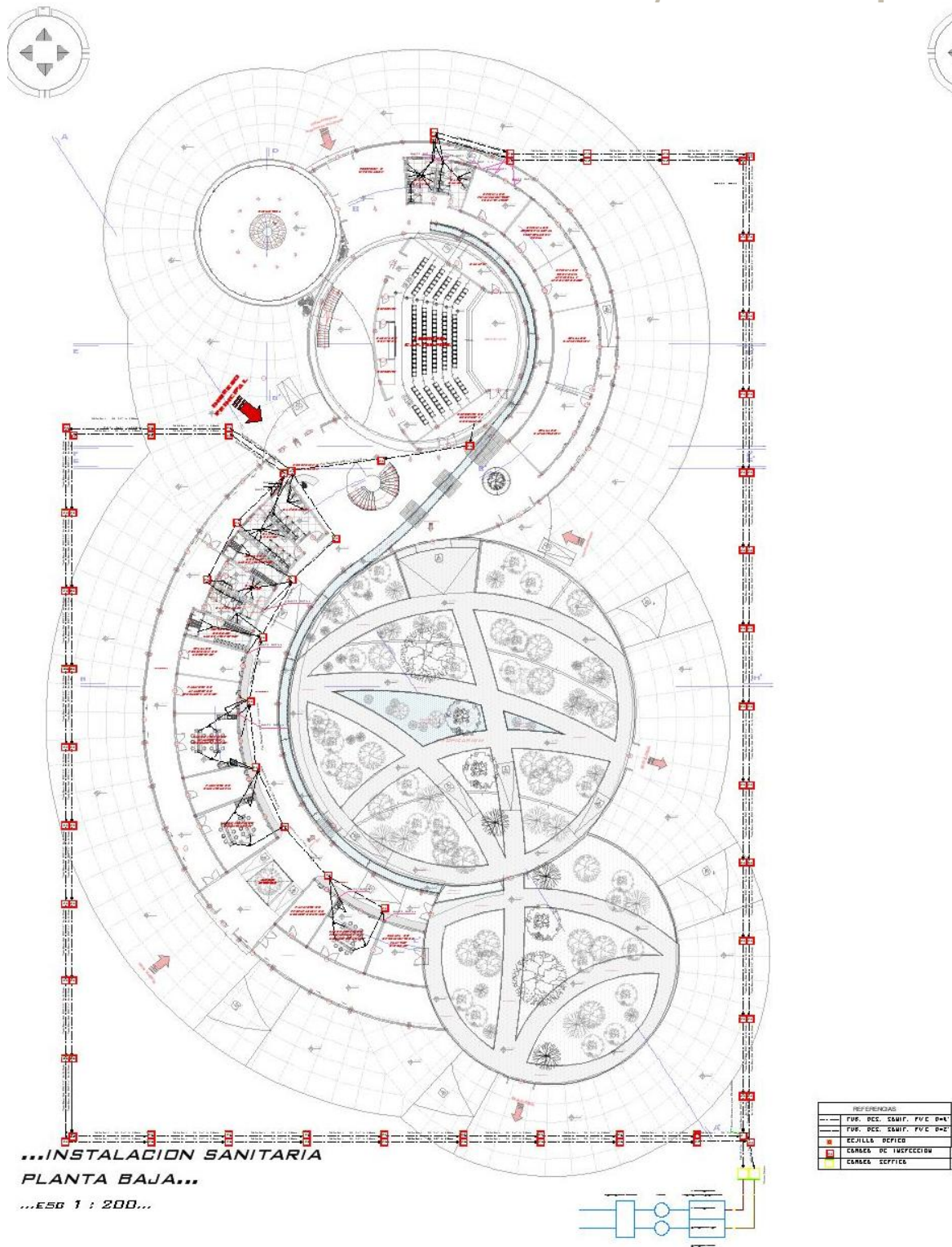

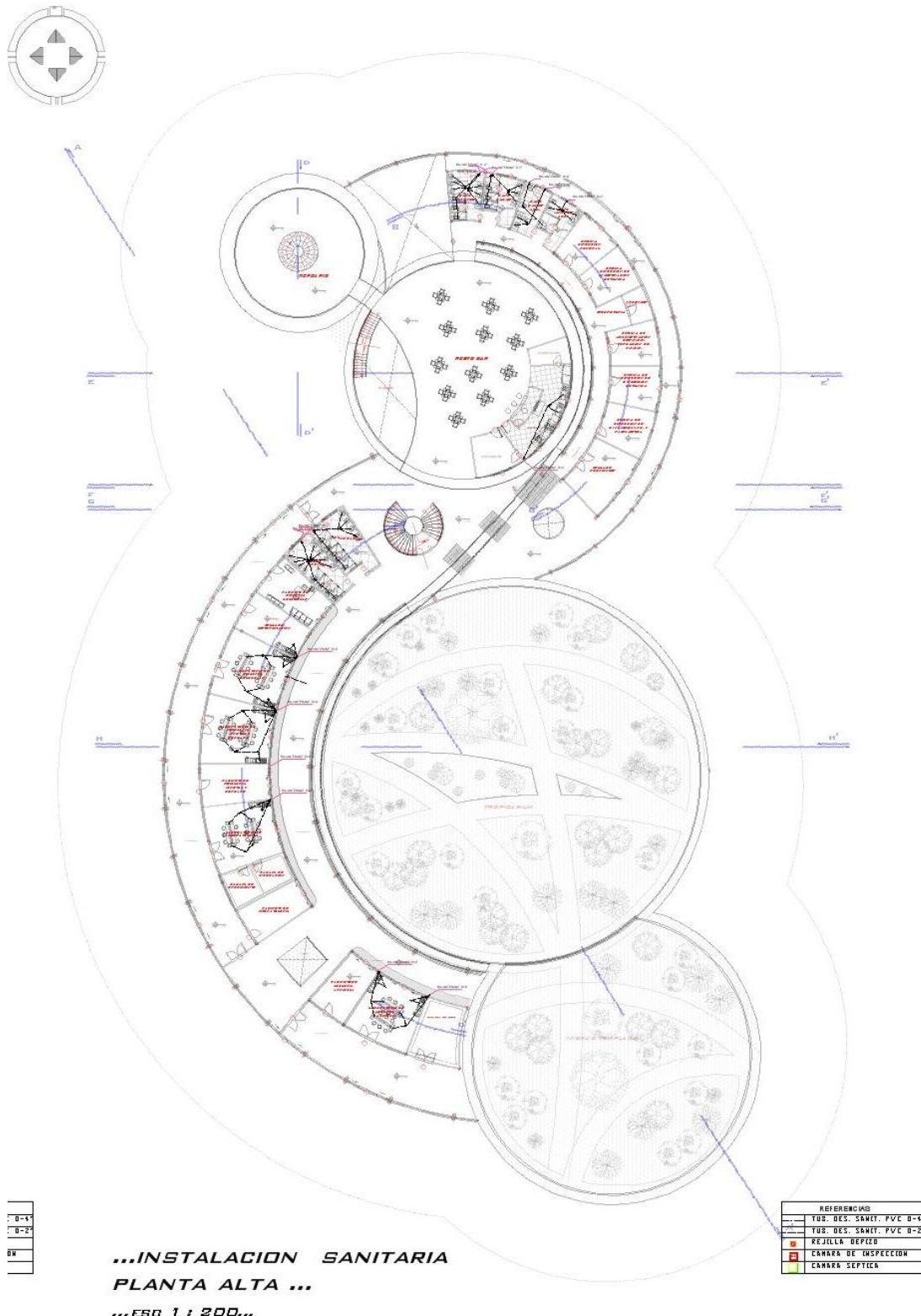

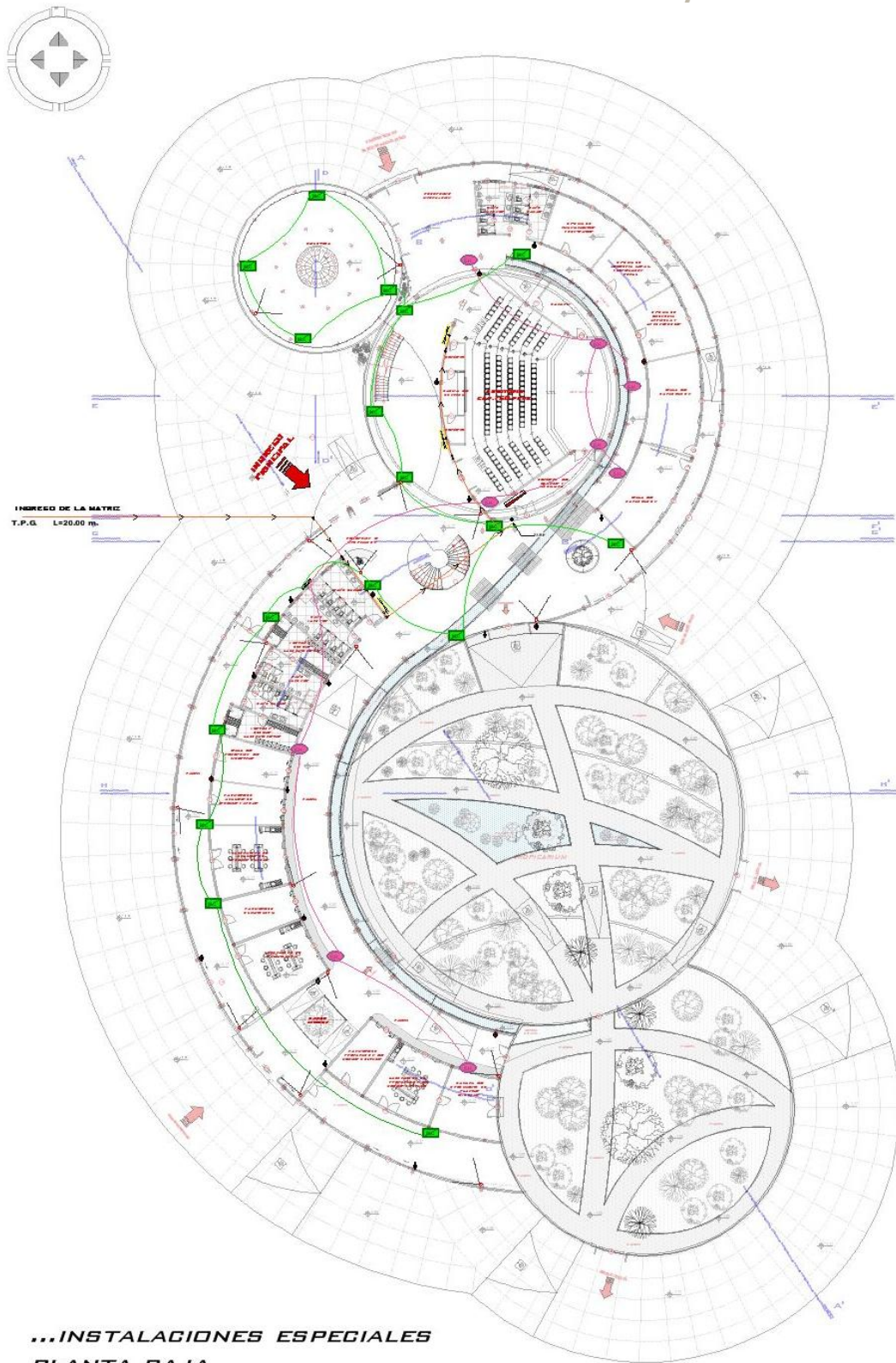

**...INSTALACIONES ESPECIALES  
PLANTA BAJA...**  
...ESC 1 : 200...

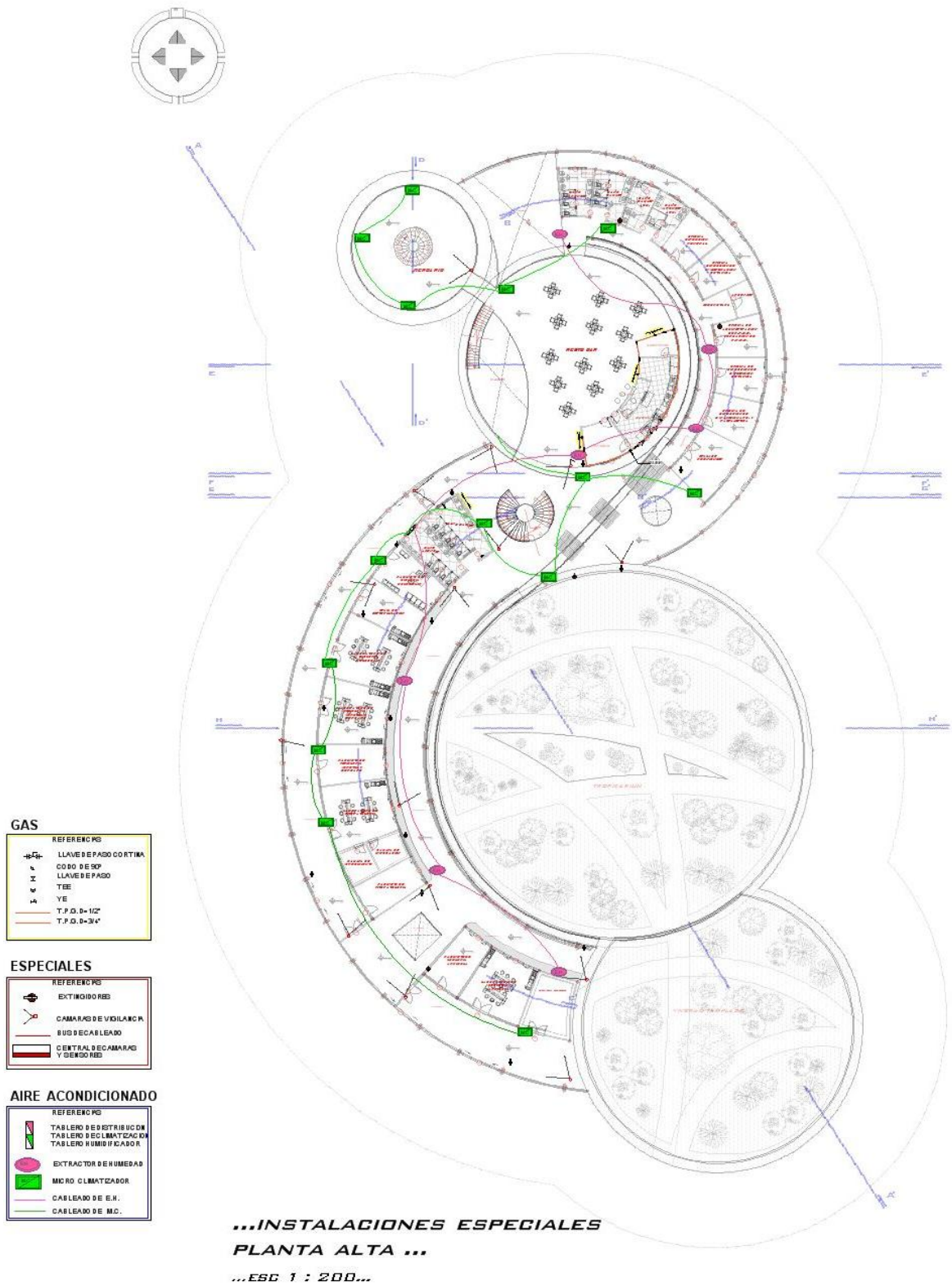

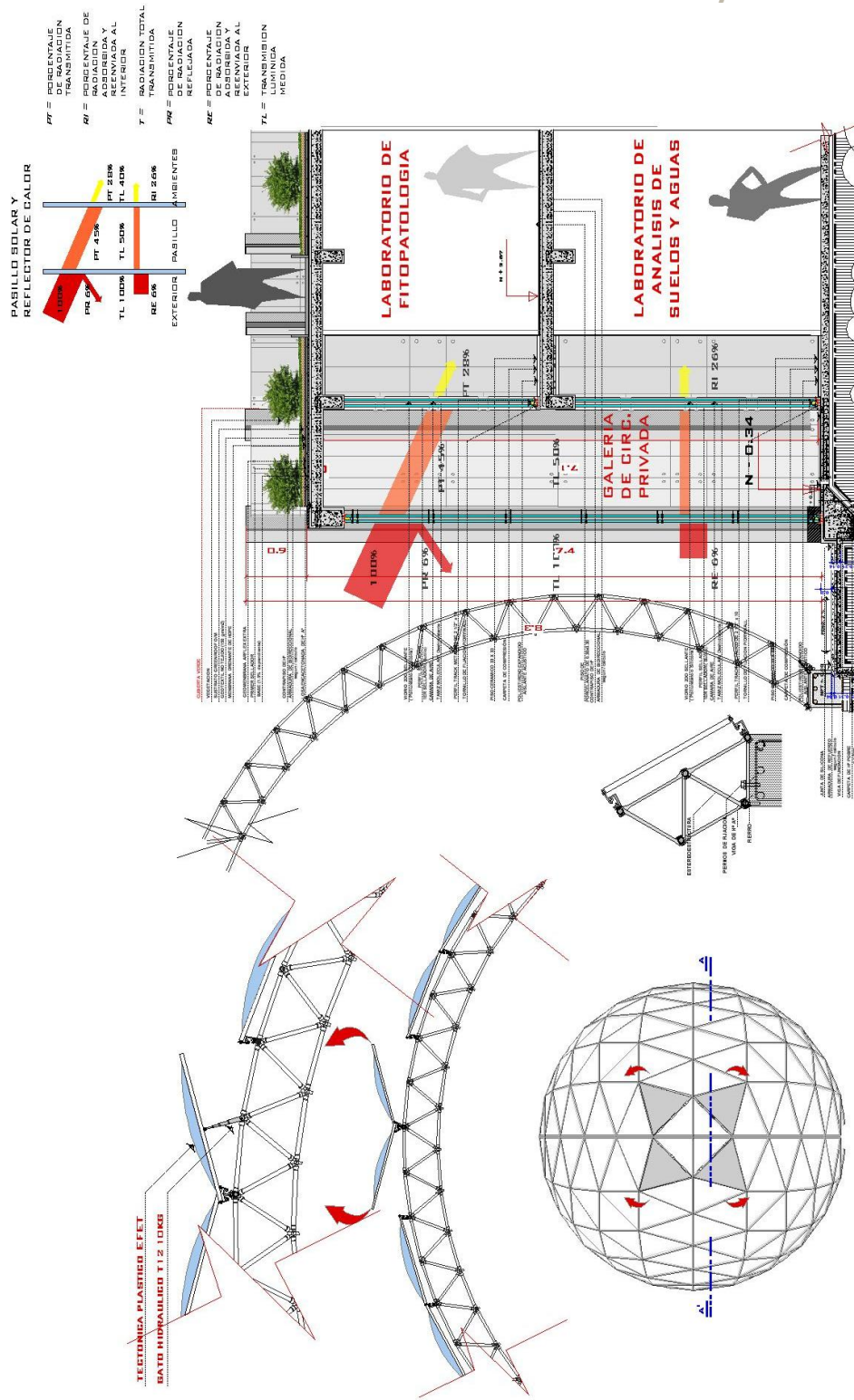

Corte de borde