



FACHADA PRINCIPAL

ESC. 1 : 200



FACHADA POSTERIOR

ESC. 1 : 200

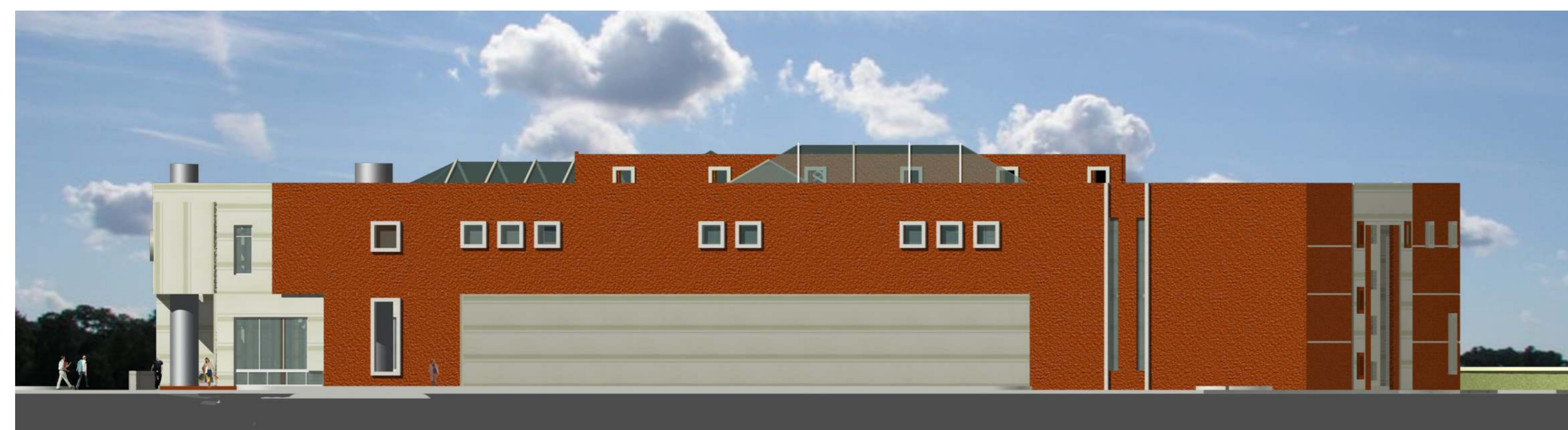

FACHADA LATERAL

ESC. 1 : 200



FACHADA LATERAL

ESC. 1 : 200



UNIVERSIDAD AUTONOMA JUAN MISAEL SARACHO
CARRERA DE ARQUITECTURA Y URBANISMO

PROYECTO:

CENTRO COMERCIAL

PLANO: FACHADAS

ESCALA : 1 : 200

DOCENTE:
ARQ. MECHTHILD KAISER

ALUMNO:
JHONNY MARTINEZ MANCILLA

LAMINA
12

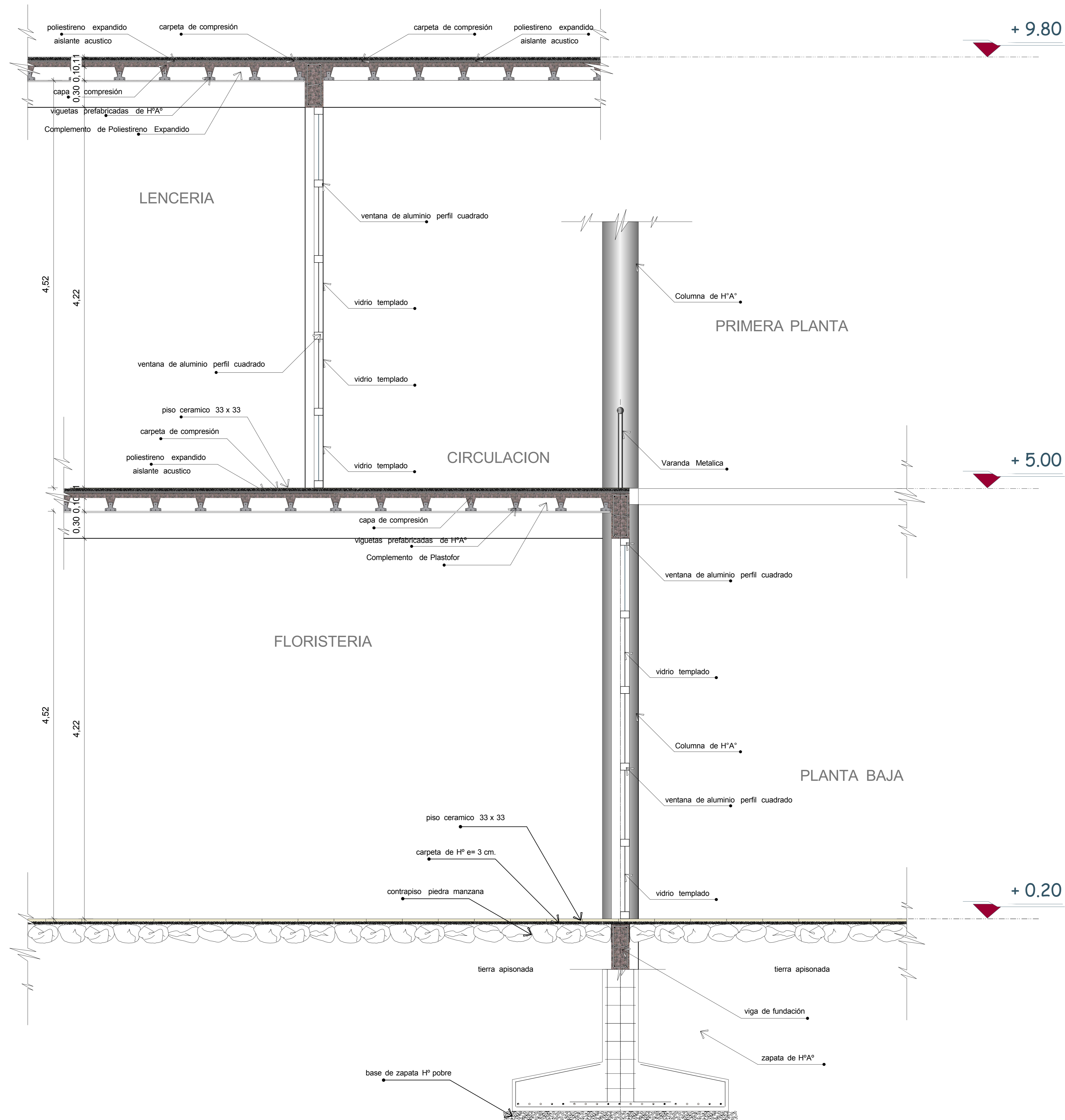

CORTE DE BORDE

ESC. 1 : 20

 UNIVERSIDAD AUTONOMA JUAN MISAEL SARACHO CARRERA DE ARQUITECTURA Y URBANISMO	PROYECTO: CENTRO COMERCIAL	PLANO: CORTES DE BORDE	DOCENTE: ARQ. MECHTHILD KAISER	LAMINA 13
		ESCALA : 1 : 20	ALUMNO: JHONNY MARTINEZ MANCILLA	

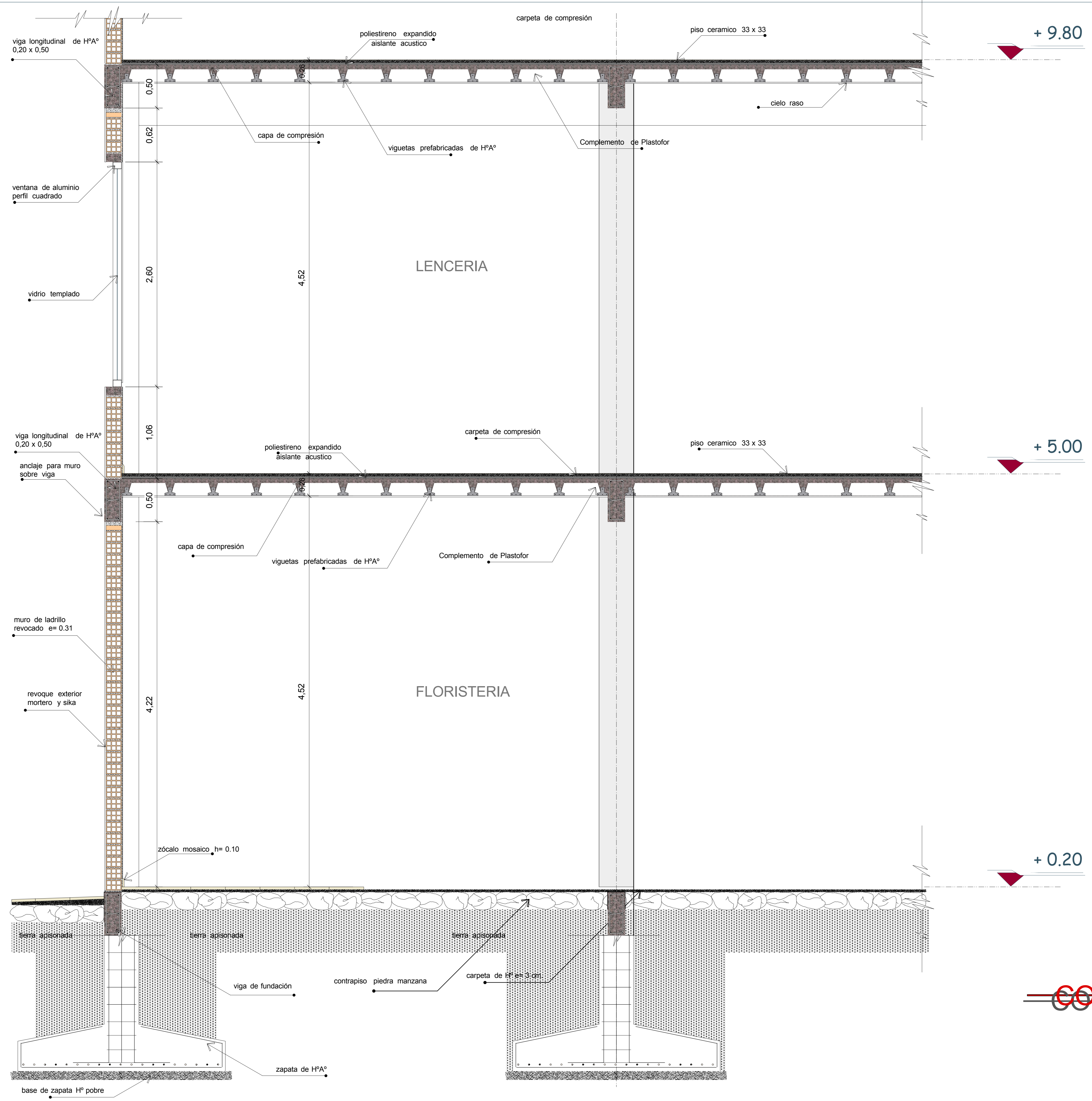

CORTE DE BORDE

ESC. 1 : 20

 UNIVERSIDAD AUTONOMA JUAN MISAEL SARACHO CARRERA DE ARQUITECTURA Y URBANISMO	PROYECTO: CENTRO COMERCIAL	PLANO: CORTES DE BORDE	DOCENTE: ARQ. MECHTHILD KAISER	LAMINA 14
		ESCALA : 1 : 20	ALUMNO: JHONNY MARTINEZ MANCILLA	

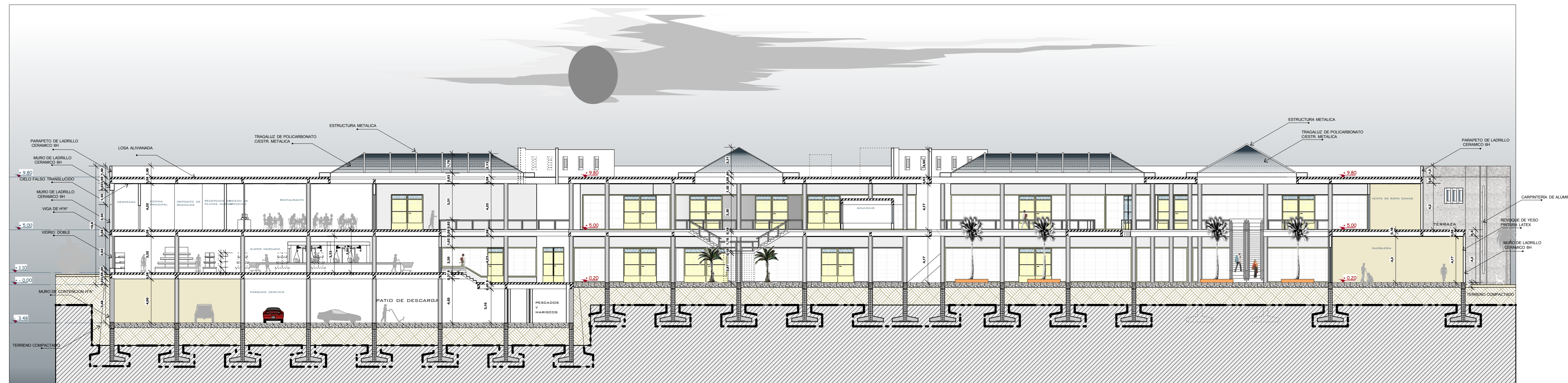

CORTE LONGITUDINAL
 ESC. 1 : 200

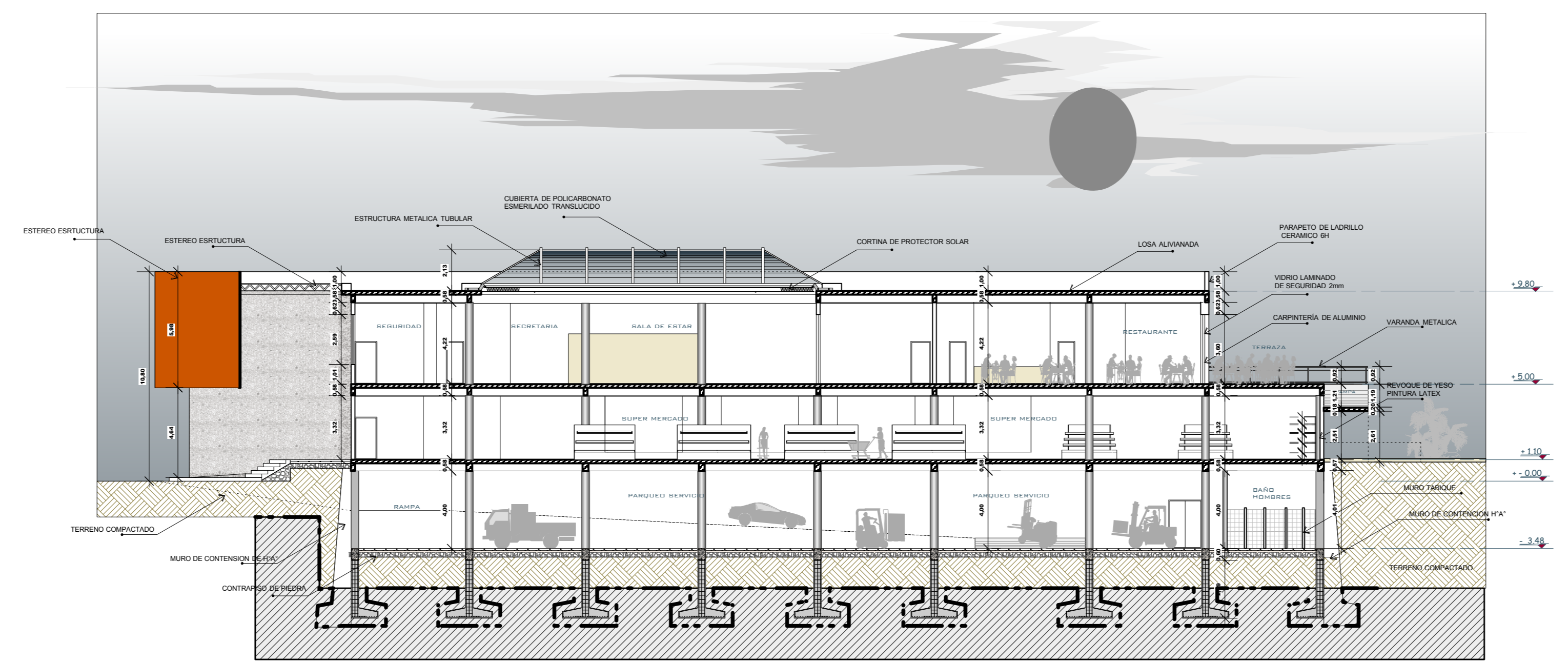

CORTE TRANSVERSAL
 ESC. 1 : 200

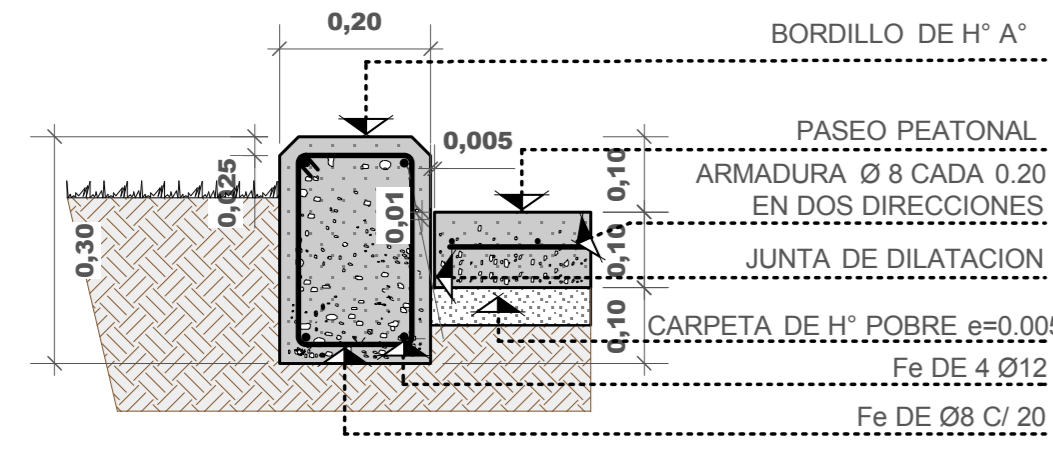

DETALLE BORDILLO DE PROTECCION RAMPAS EXTERNAS

ESCALA 1 : 10

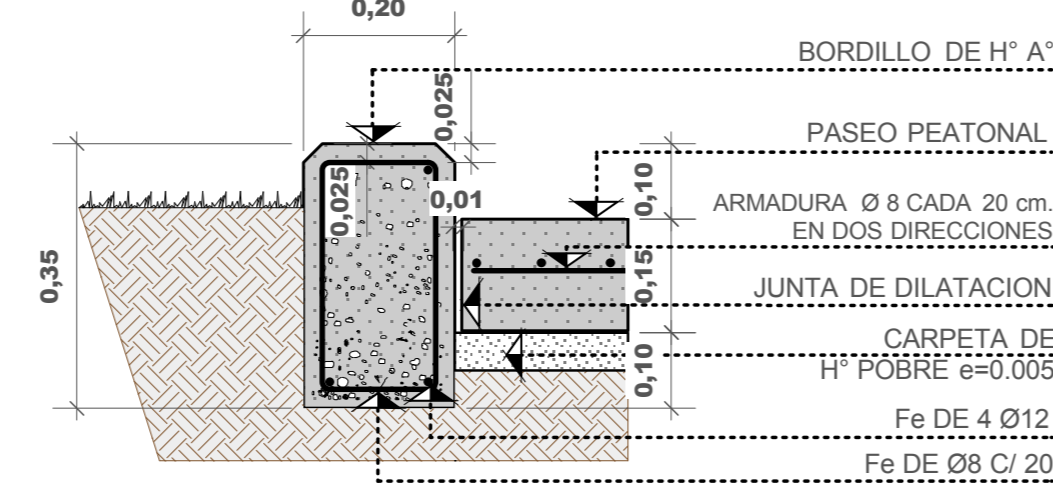

DETALLE BORDILLO INGRESO PEATONAL

ESCALA 1:10

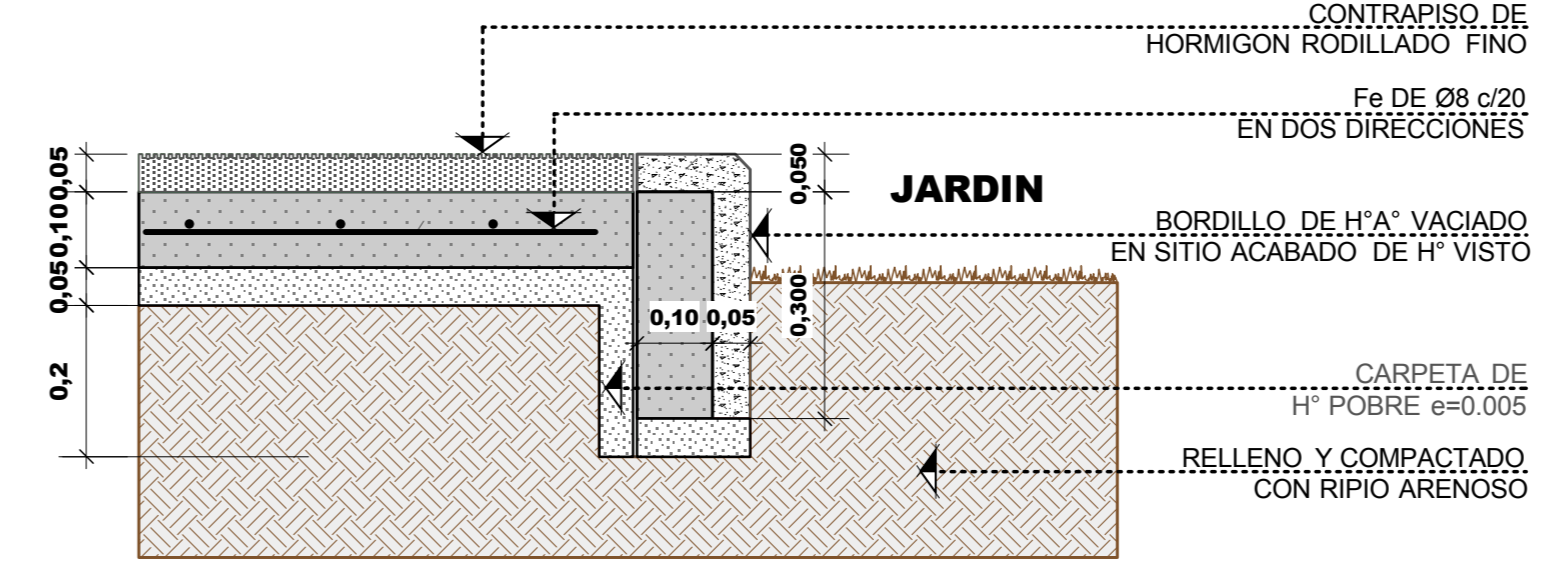

DETALLE ENCUENTRO ACERAS Y JARDINES

ESCALA 1:10

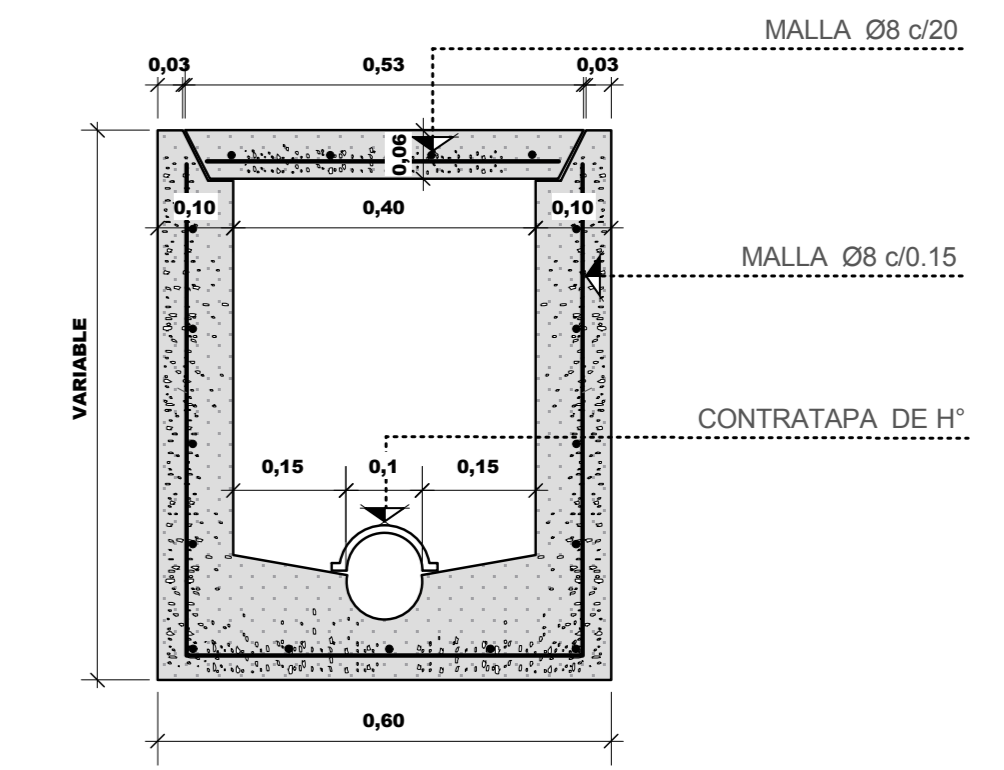

SECCION CAMARA SIMPLE

ESCALA 1:10

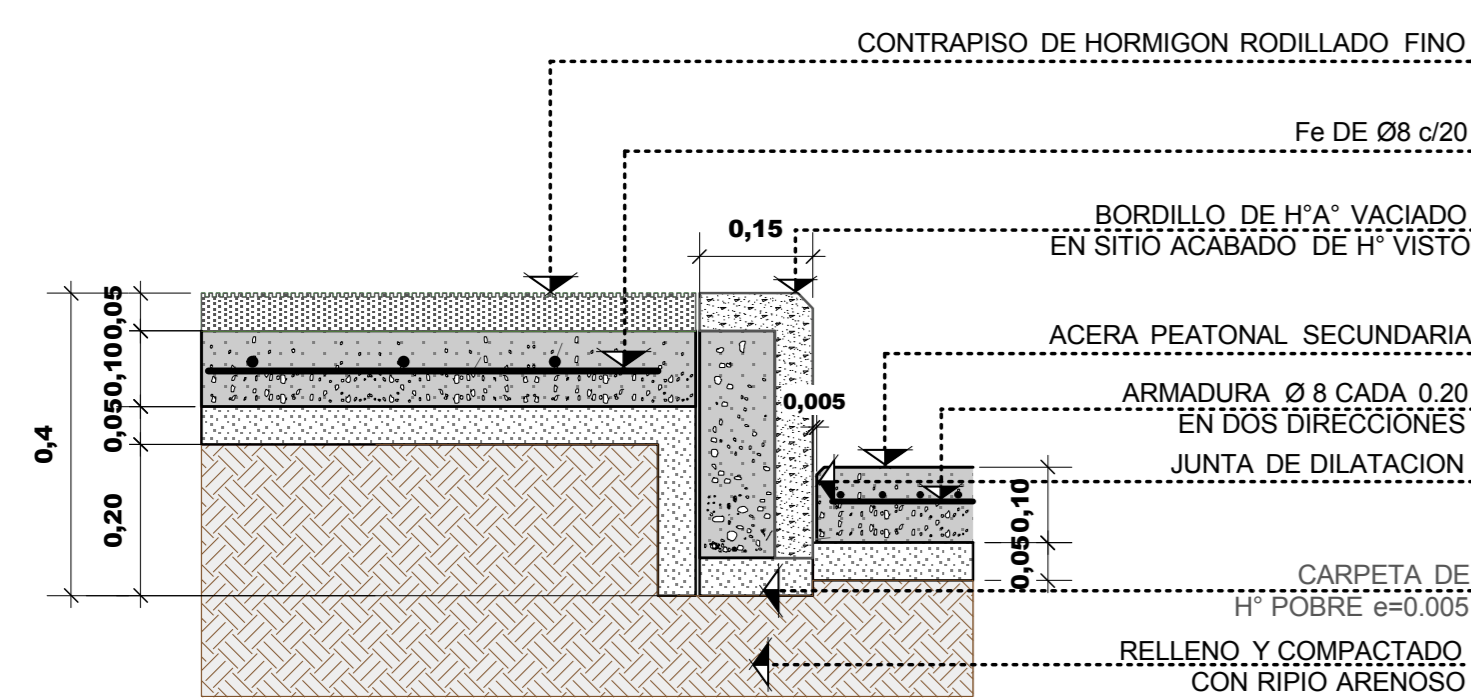

DETALLE DE ENCUENTRO DE ACERAS CON PISO H° A°

ESCALA 1:10

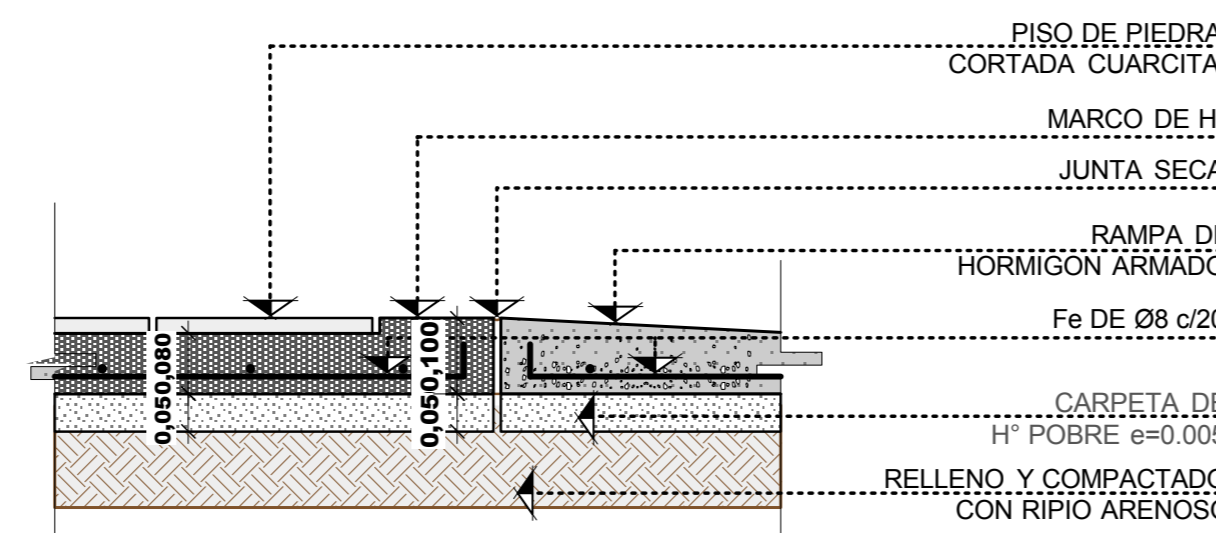

DETALLES ENCUENTRO PISO CON RAMPA

ESCALA 1:10

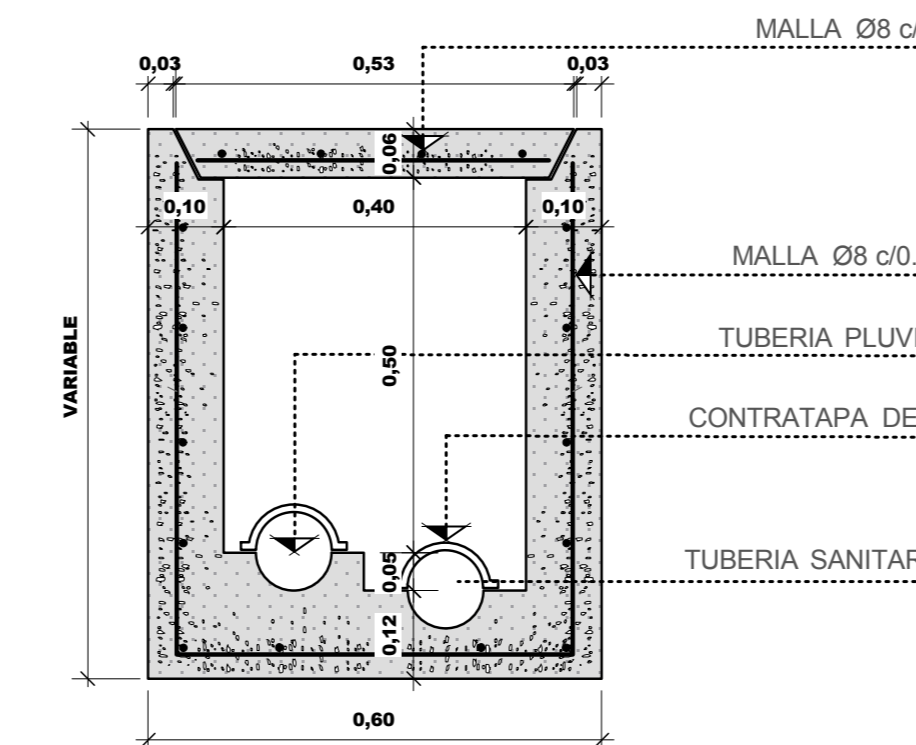

SECCION CAMARA DOBLE

ESCALA 1:10

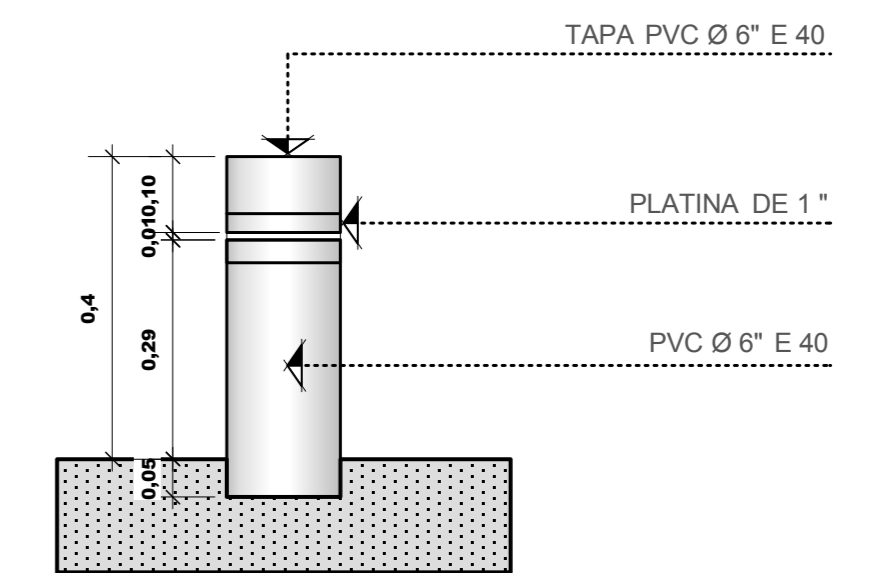

ELEVACION PILA DE RIEGO

ESCALA 1:10

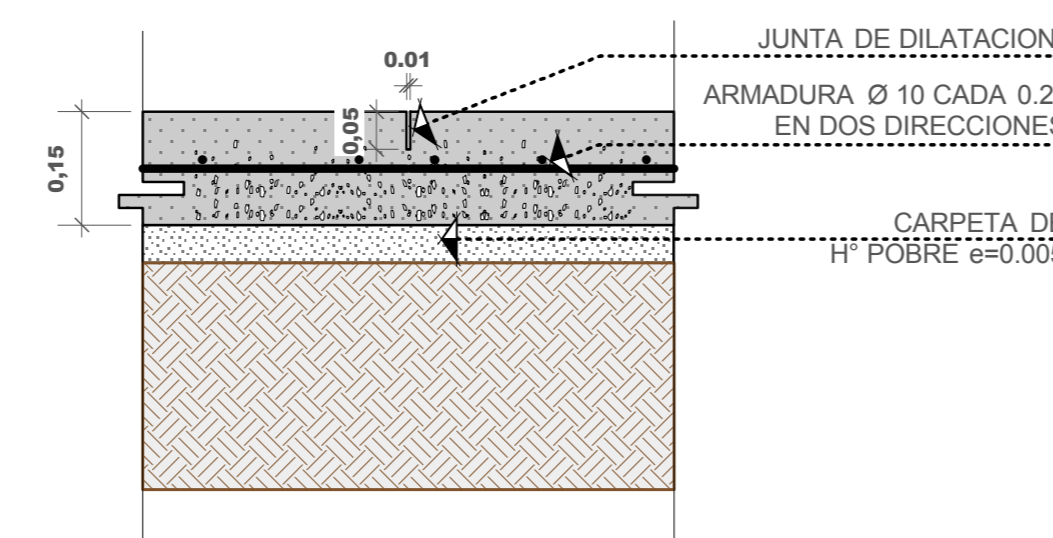

PISO DE H° A° CIRCULACION VEHICULAR

ESCALA 1:10

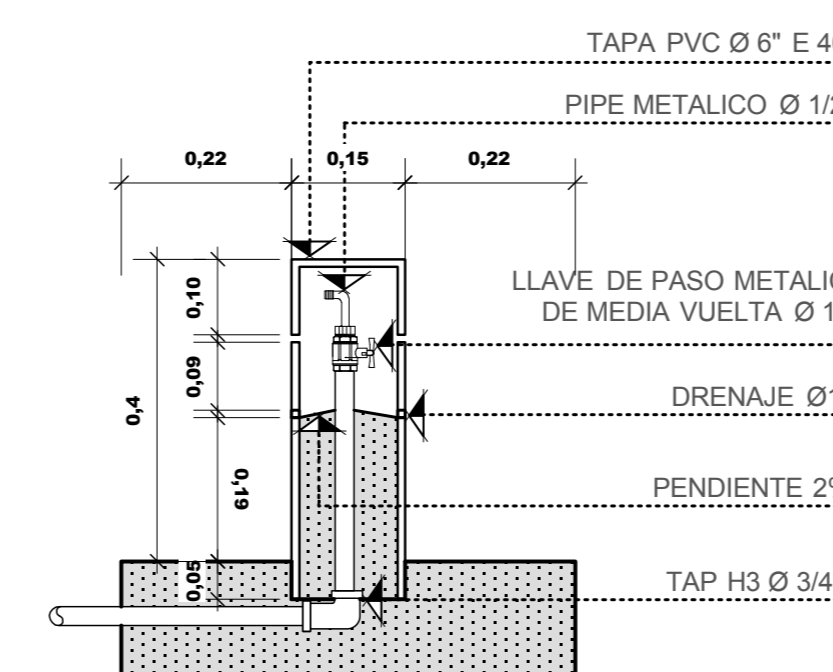

SECCION PILA DE RIEGO

ESCALA 1:10

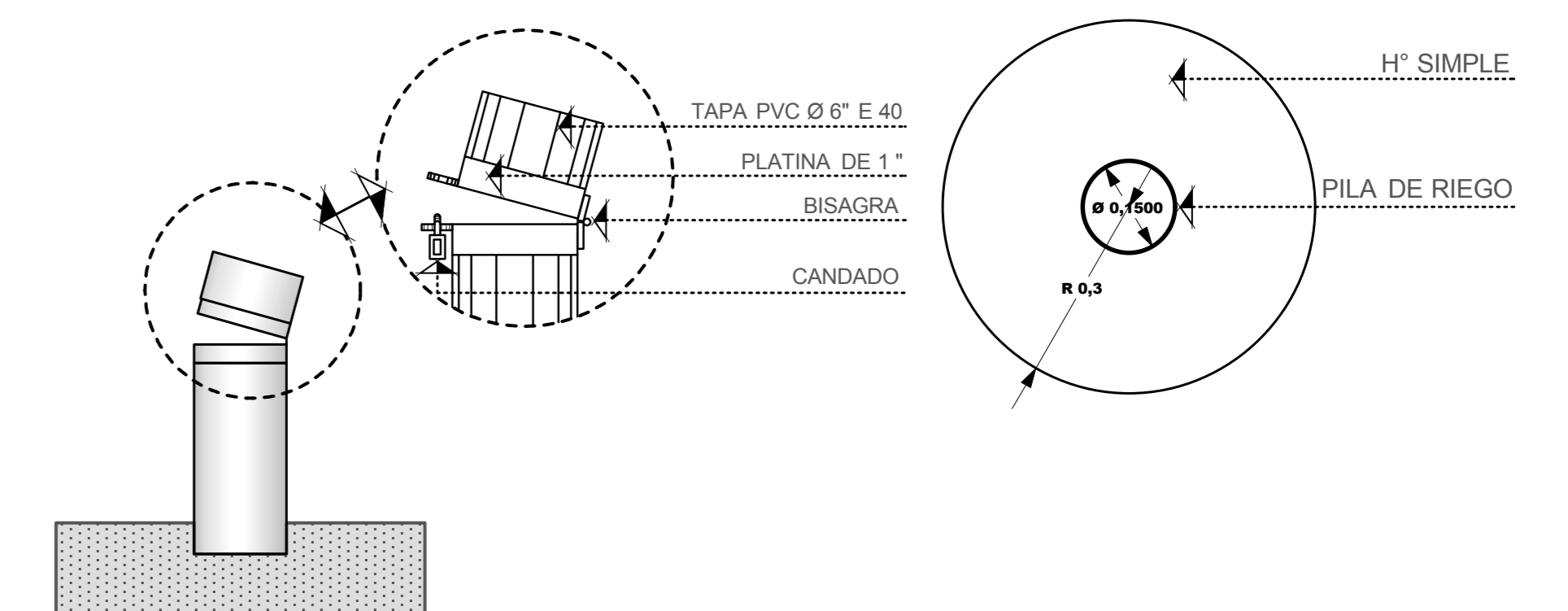

DETALLE PILA DE RIEGO

ESCALA 1:10

MARCO CONSTRUIDO CON PLETINA DE 50x3 mm ANCLADO CON PATAS AL PERIMETRO DE LA CAMARA TAPA CONSTRUIDA EN HORMIGON Y ESTRUCTURADA CON PLETINA DE 70 x 3 MM Y ARMADURA Y 8 PINTADAS CON OCRE VERDE

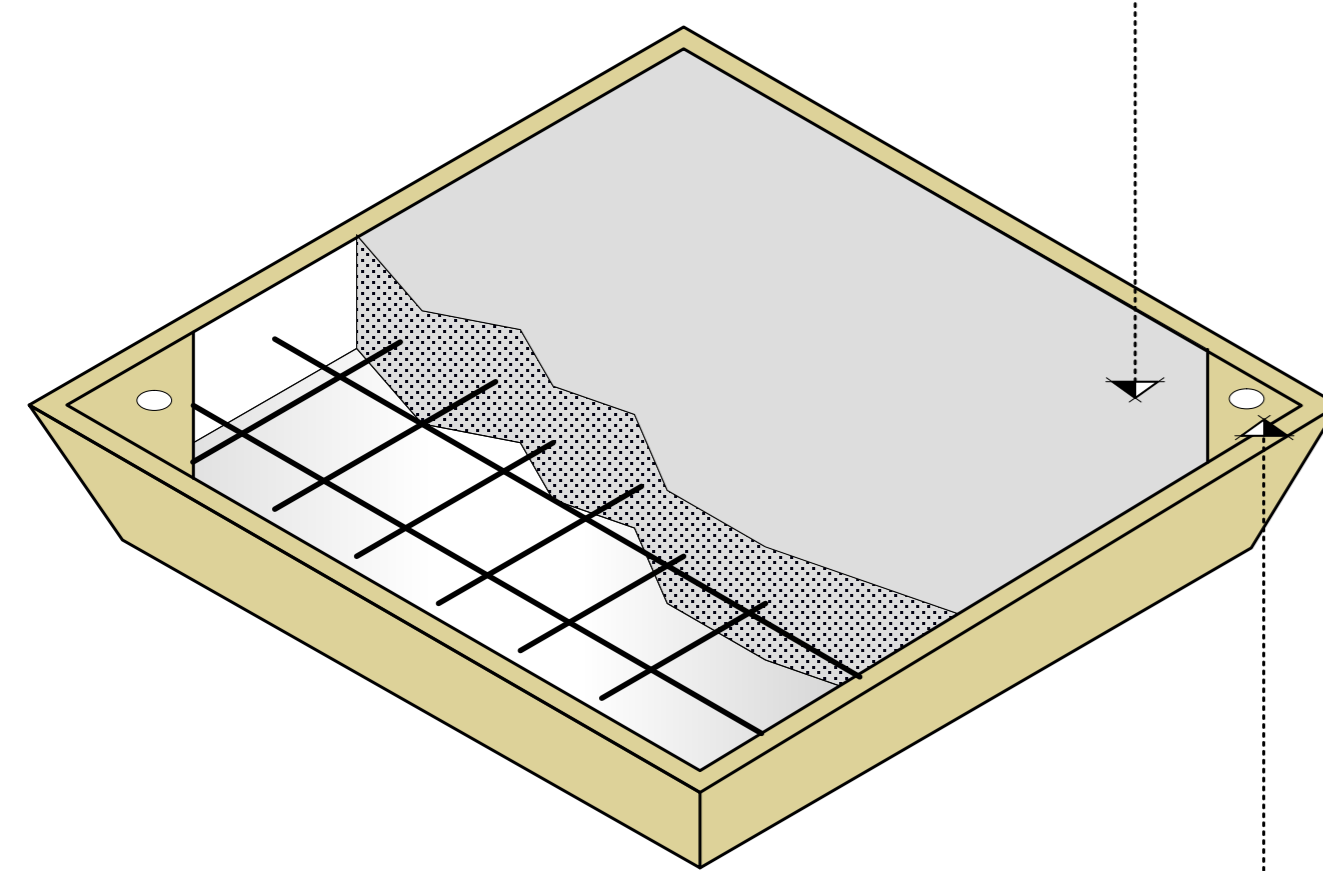

TAPA DE H° CAMARA DE INSPECCION

ESCALA 1:5

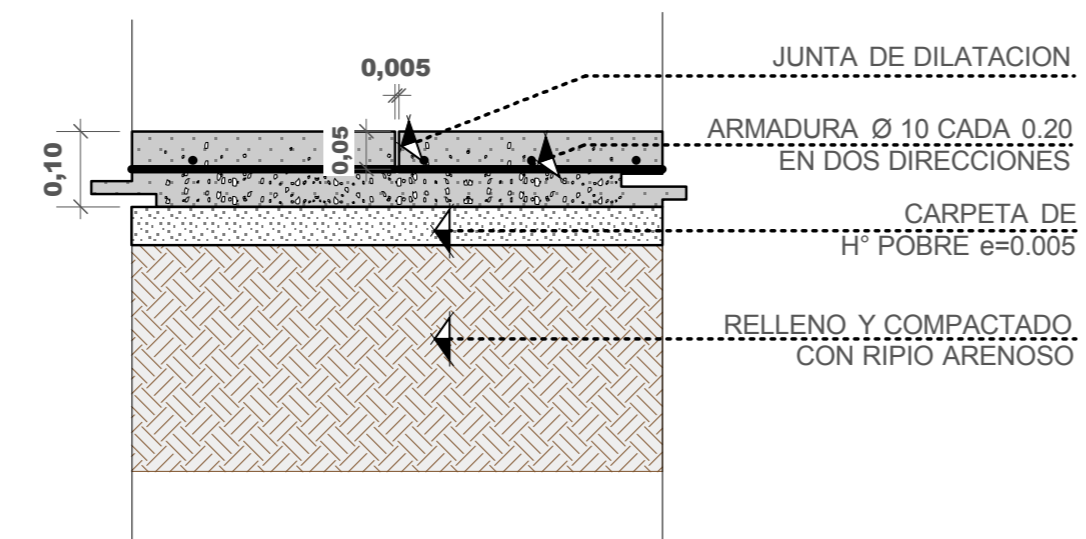

PISO DE H° A° CIRCULACION PEATONAL

ESCALA 1:10

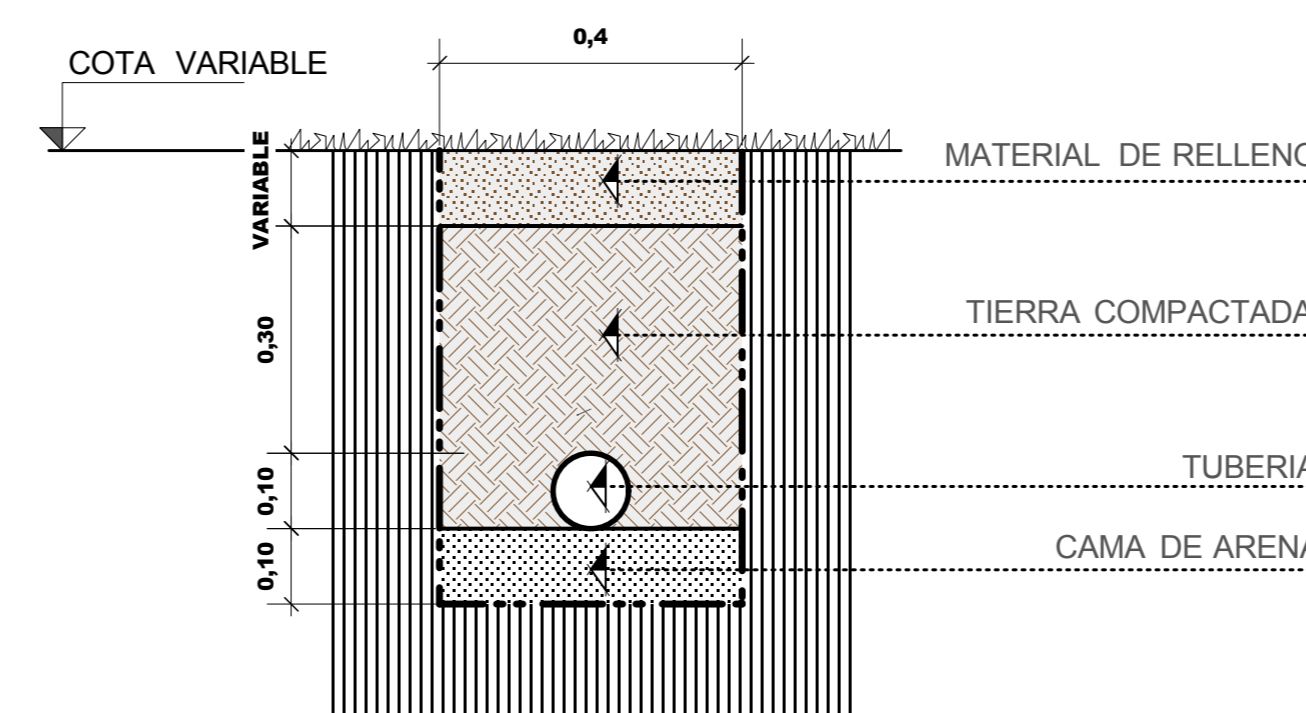

TUBERIA DE ALCANTARILLADO DE AGUA POTABLE

ESCALA 1:10

DETALLES CONSTRUCTIVOS



UNIVERSIDAD AUTONOMA JUAN MISAE SARACHO
CARRERA DE ARQUITECTURA Y URBANISMO

PROYECTO:

CENTRO COMERCIAL

PLANO: DETALLES ACERAS- PILA DE RIEGO

DOCENTE:
ARQ. MECHTILD KAISER

ESCALA : 1 : 10 - 1 : 5

ALUMNO:
JHONNY MARTINEZ MANCILLA

LAMINA
16

DETALLE DE FUNDACION

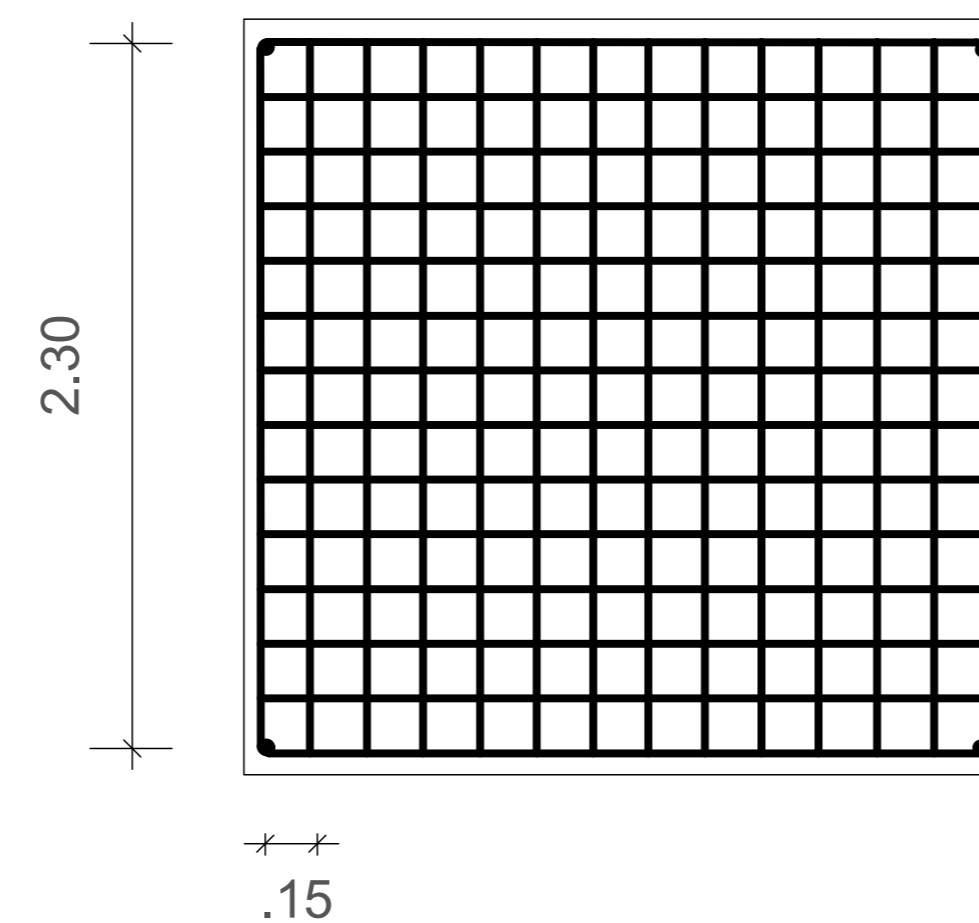
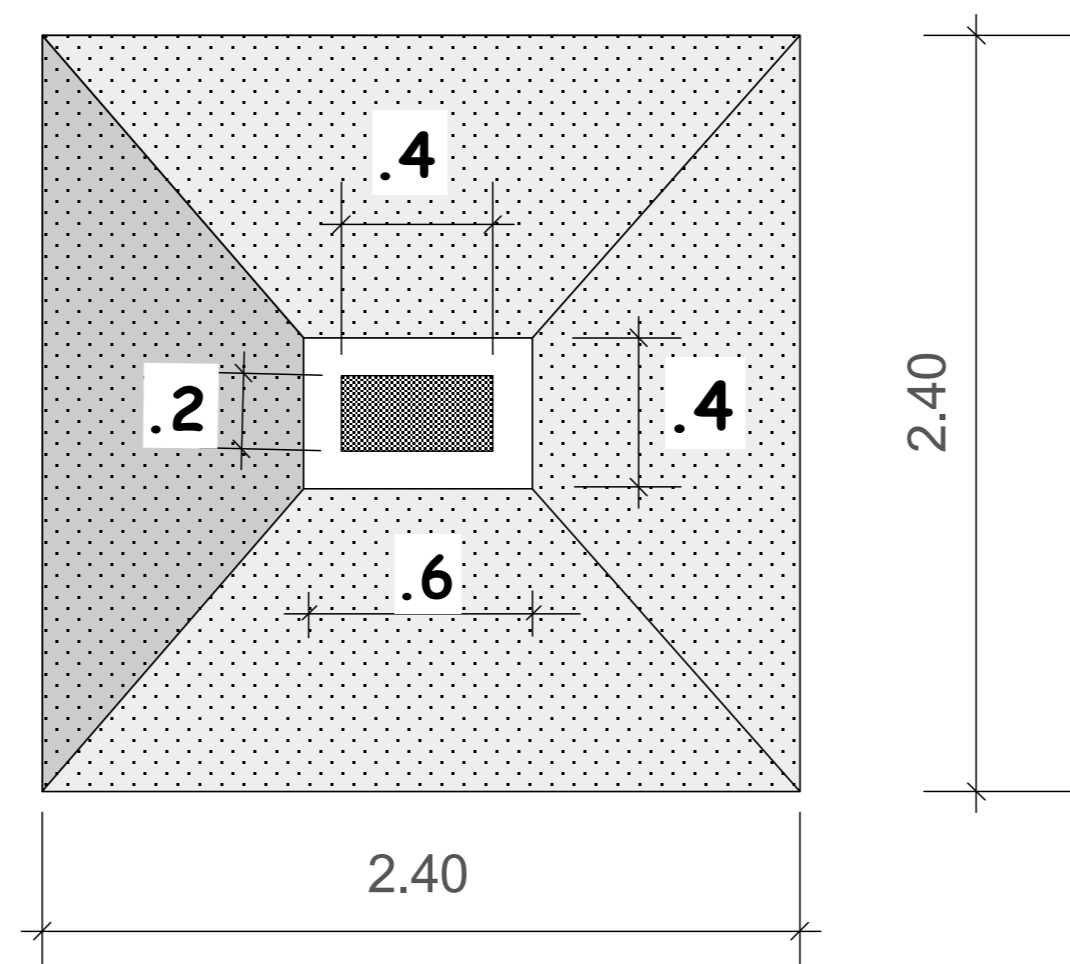
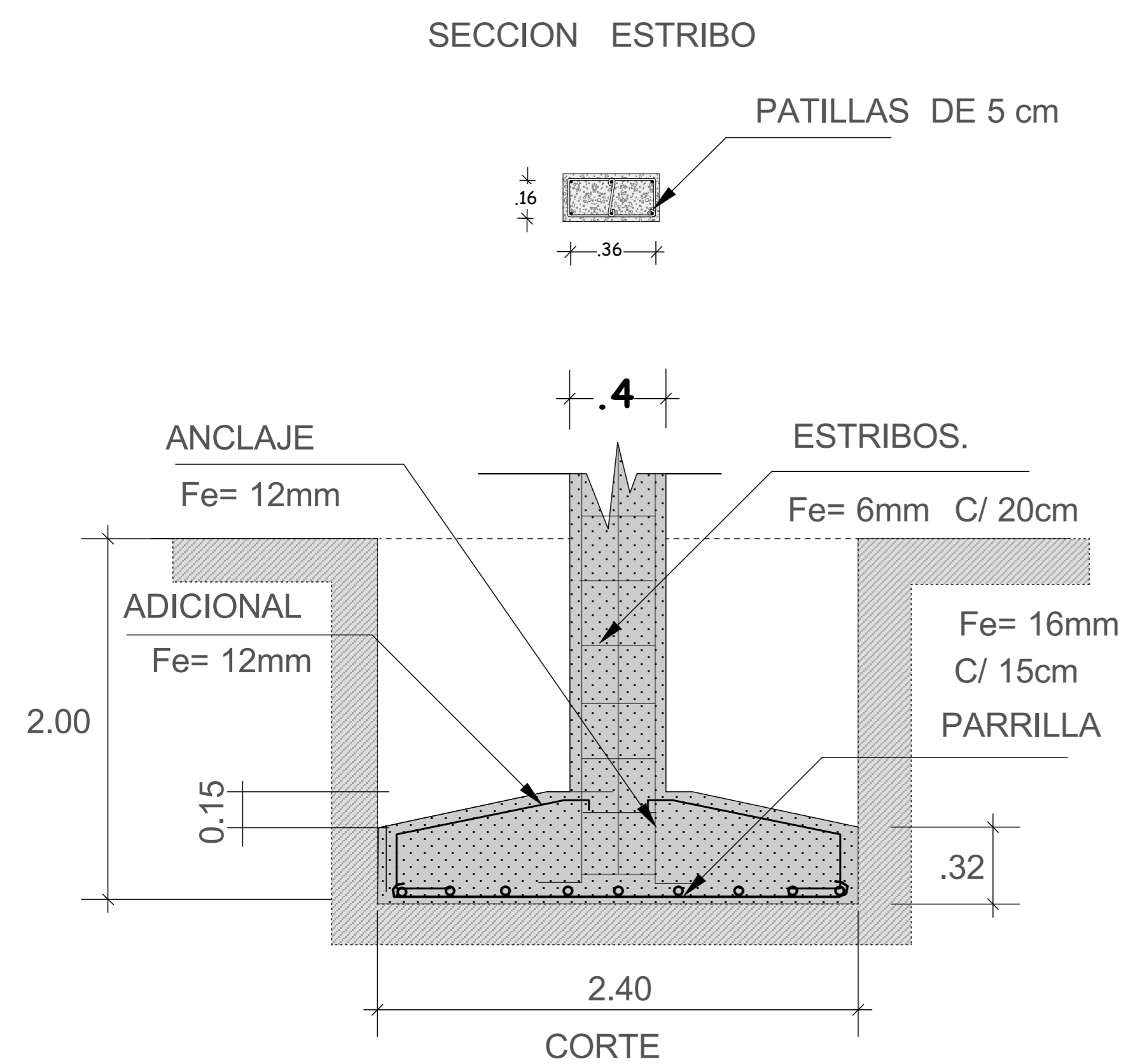

DETALLE DE TANQUE BAJO

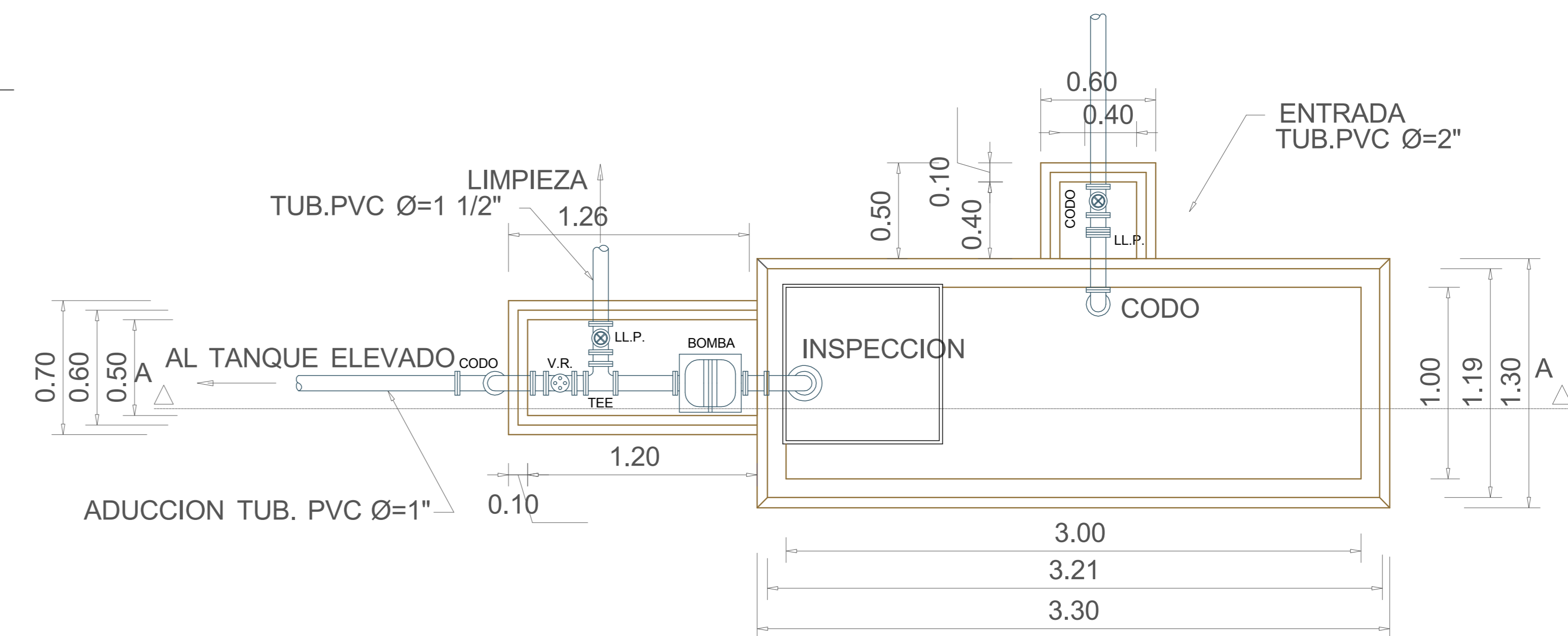

PLANTA DE TANQUE DE H° A°

ESCALA 1 : 50

DETALLE DE ZAPATA

ESCALA 1 : 20

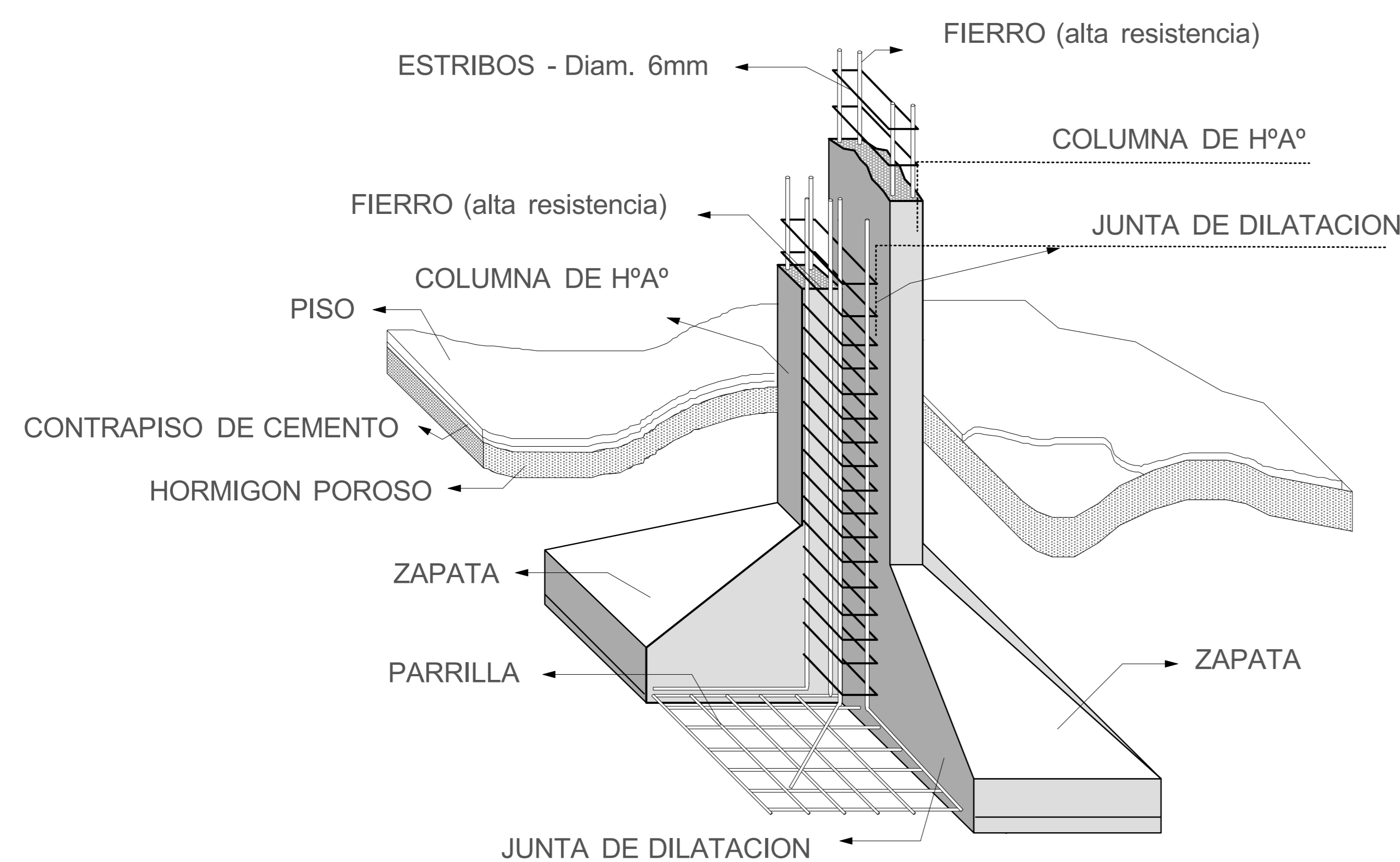

PERSPECTIVA DE ZAPATA

ESCALA 1 : 20

PARRILLA

ESCALA 1 : 20

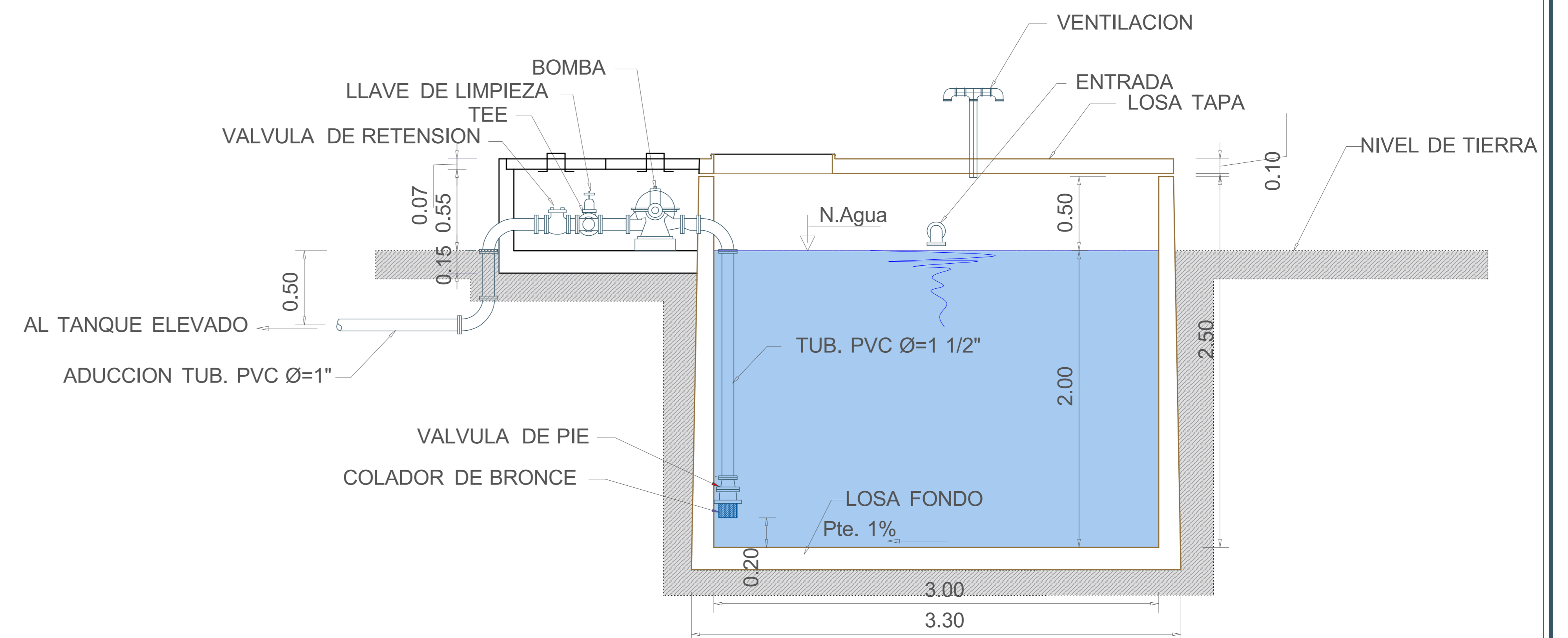

CORTE A - A

ESCALA 1 : 50

~~DETALLES CONSTRUCTIVOS~~



UNIVERSIDAD AUTONOMA JUAN MISAEL SARACHO
CARRERA DE ARQUITECTURA Y URBANISMO

PROYECTO:

CENTRO COMERCIAL

PLANO: DETALLES

ESCALA :

1 : 10 - 1 : 5

DOCENTE:
ARQ. MECHTHILD KAISER

ALUMNO:
JHONNY MARTINEZ MANCILLA

LAMINA
17

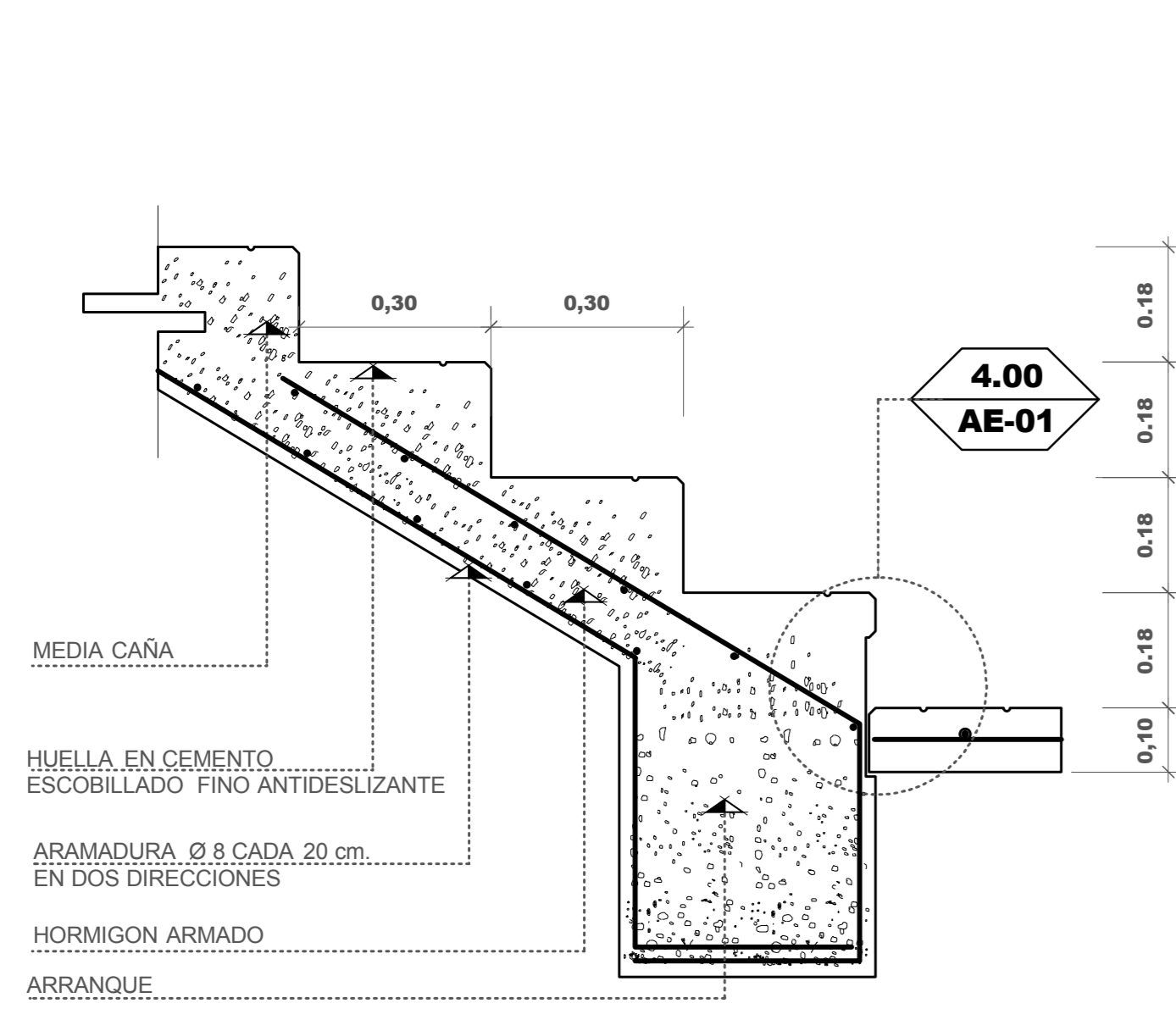

GRADA EXTERIOR

ESCALA 1:10

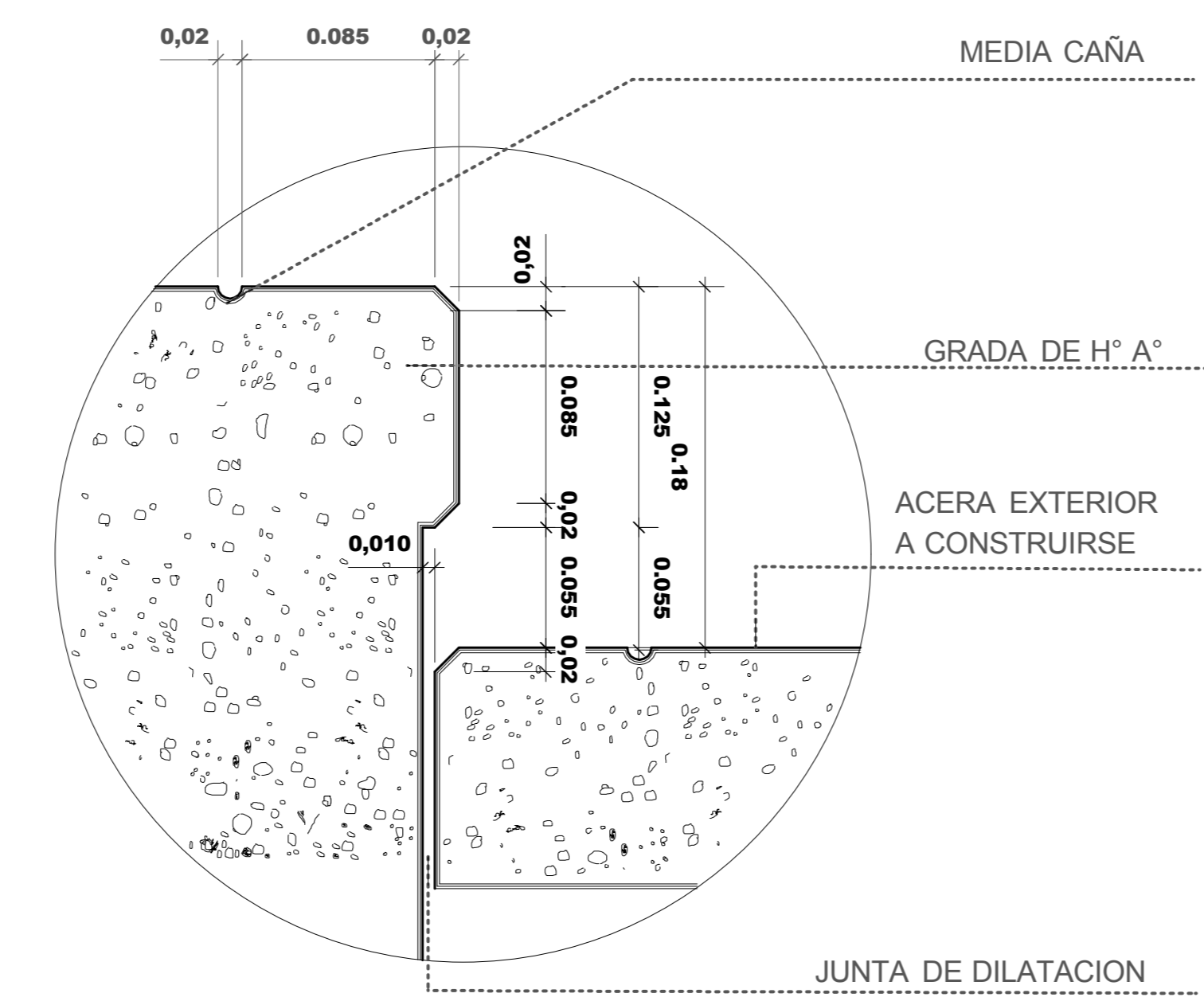

GRADA EXTERIOR

ESCALA 1:5

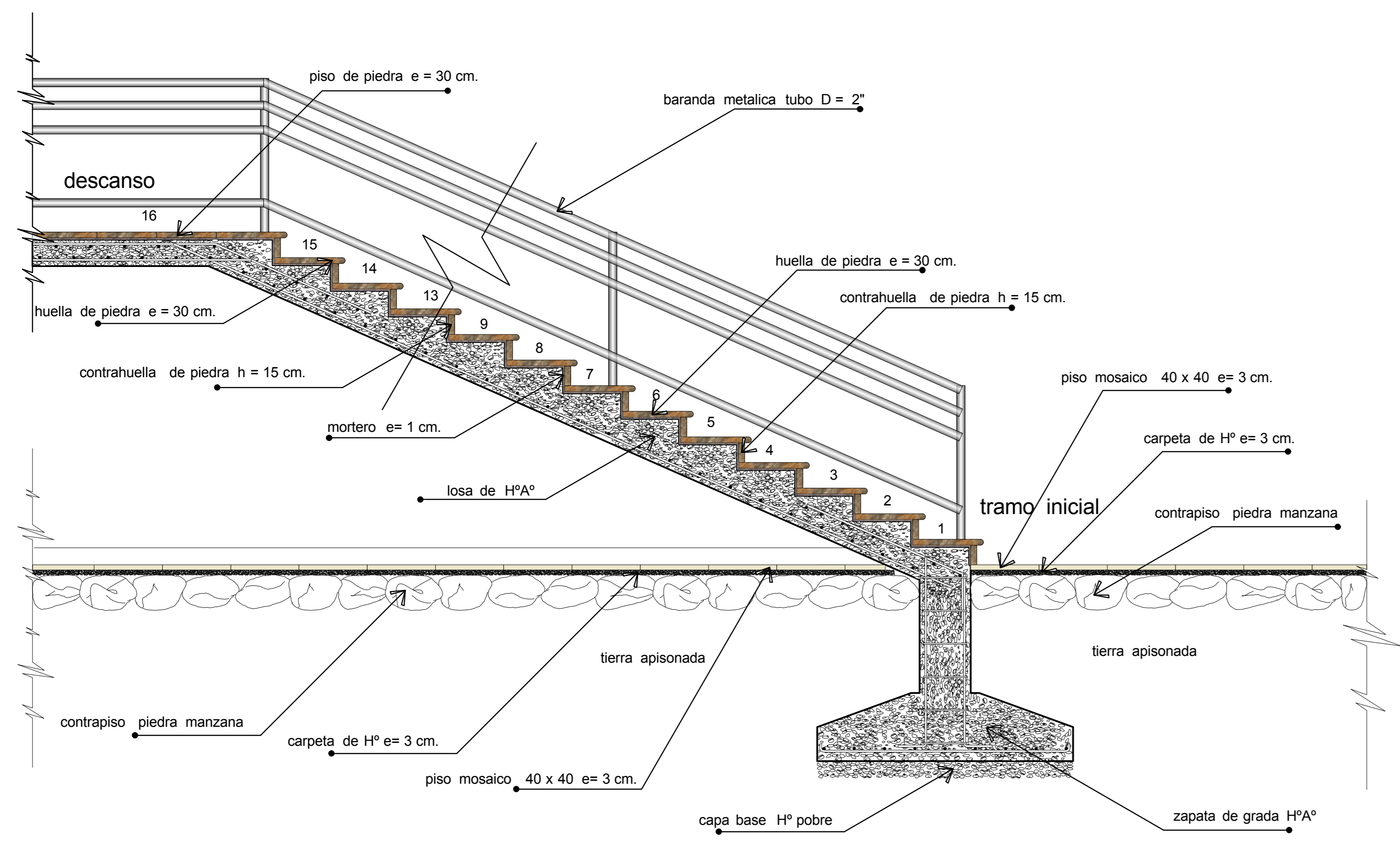

GRADA INTERIOR

ESCALA 1:20

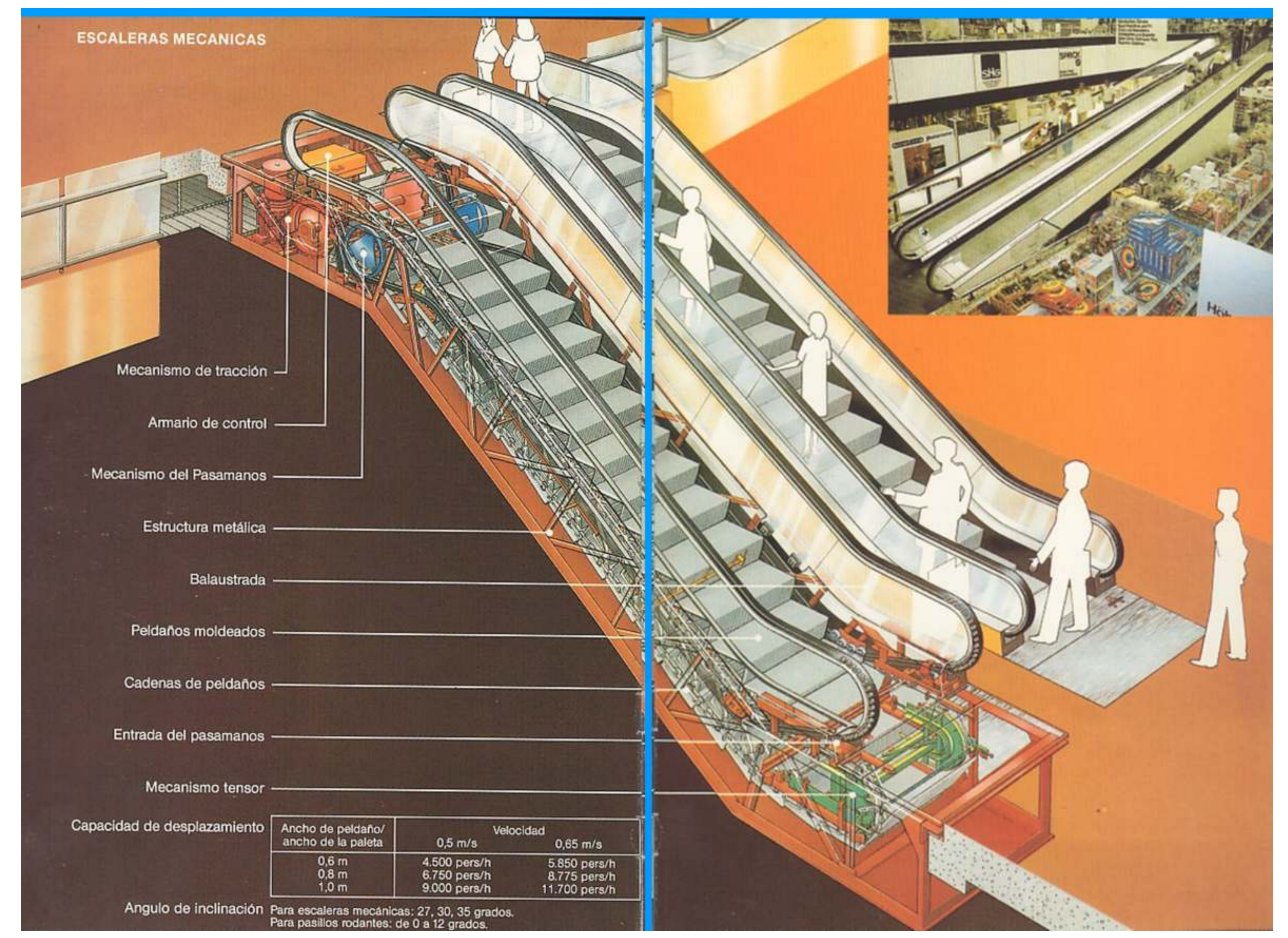

DETALLES CONSTRUCTIVOS